

BLENDERS

Precision Blending

world of innovation

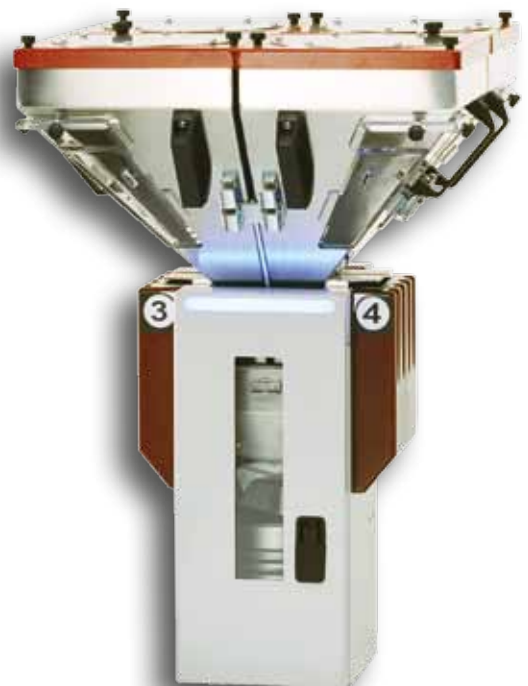

THE ULTIMATE IN PRECISION BLENDING

Modularity

Removable material hopper lid c/w cover plate fits prebolted FEEDMAX series hopper loader flange.

Unique "Clip-on" corner window

Simple "clip-on" corner window provides full view for material inspection and detaches quickly for simpler, easier cleaning access compared to other designs.

Highest precision

Two independent 24-bit technology load cells provide more precise, noise-free weight signal readings than single load cell systems.

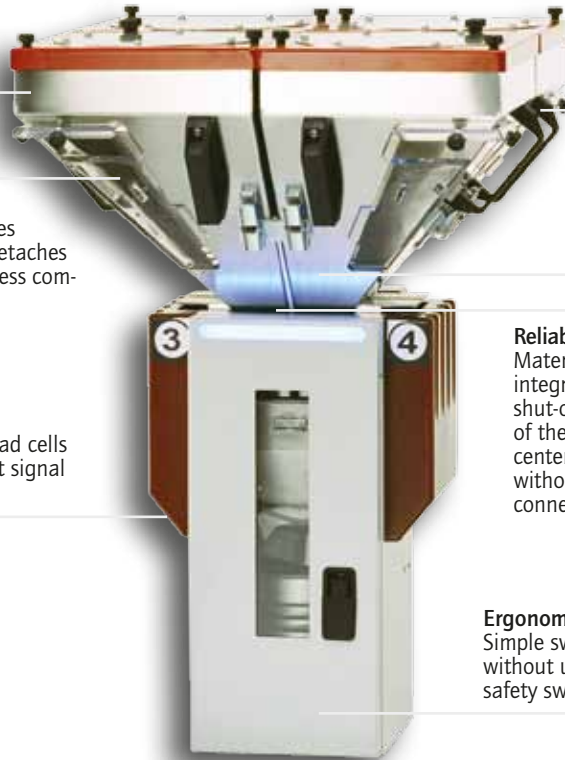

Easy handling

Two handles allow safe easy handling of material hoppers.

Easily removable

Material hoppers made entirely of wear resistant stainless steel and are equipped with self-locking toggle latches.

Reliable material dispensing valves

Material hoppers with normally closed integral dispensing valves for positive shut-off. The actuating mechanism of the dispensing valve is part of the center body for simple hopper handling without unpractical or unsafe hose or wire connections.

Ergonomic and dustproof

Simple swing door, opens via quick fastener without using tools. The door is secured by a safety switch.

ADVANTAGES OF GRAVIMAX BLENDERS



Simple operation

- » Ingredient values entered as ratio or in % via touch-screen.
- » Changing recipes without stopping.
- » Material data base, progress display.
- » Storage of 500 recipes, inventory reports.
- » Preset batch count.



Highly precise metering valves

Unique flow-valves made from stainless steel for high abrasive wear applications are extremely fast, efficient and consistently reliable. Major ingredients and additives are precisely metered to the desired set point.



Interchangeable steel hoppers

Self-closing valve mechanism offers easy cleaning and color change. The hopper is specially designed with no flow restricting or bridging parts in the hopper. Two convenient handles allow safe and easy material hopper handling.

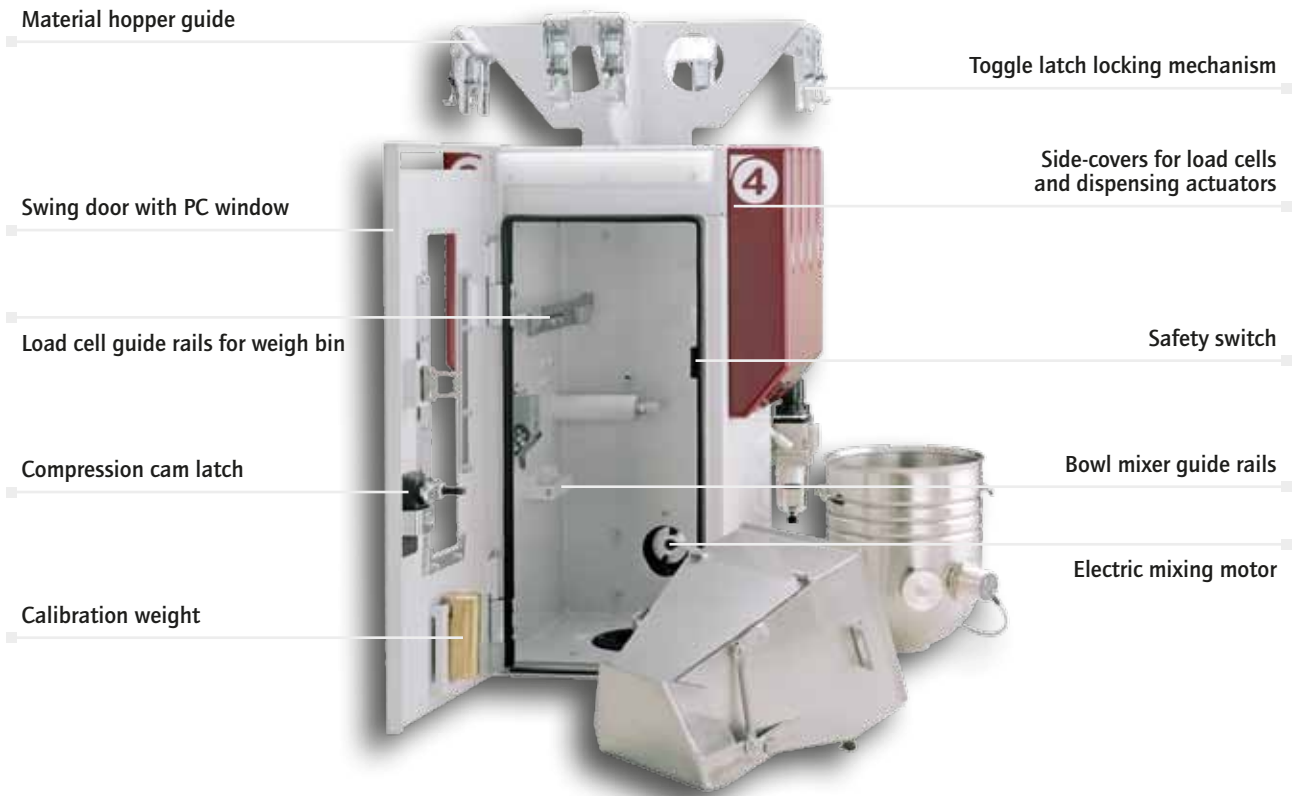

"Clip-on" corner window

Unique "clip-on" corner window provides full view for material inspection. The corner window detaches quickly for simpler and easier cleaning access compared to other blender designs.



Easily removable weigh bin

Two weigh cell slide bars and a 60° discharge angle geometry provide complete emptying after each batch. The self-closing discharge flap mechanism prevents release of material from the weigh bin in the event of pressure loss.



Uniform material blending

Highly efficient spiral mixer provides a homogeneous material blend and allows for easy cleaning. The hemispherical geometry of the spiral mixer guarantees no dead spots or material hang-up.

RTLS TECHNOLOGY

Material Savings Reduce Cost

A unique 2-stage metering method achieves the most precise dispensing for batch-to-batch consistency and accuracy. This is accomplished by using progressively smaller dispensing algorithms to approach the target weight. Only one standard high precision valve is used for pellets, regrind, additives.

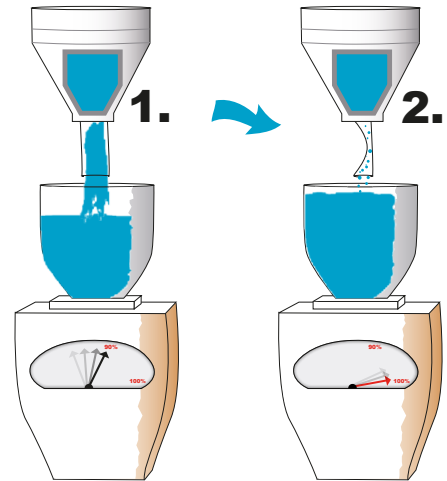

Step 1: Free flow
Quick dispensing to near target weight.

Step 2: Fine pulsing
Controlled high frequency dispensing precisely to target.

Batch-to-batch accuracy means no overuse of high cost resins, optimizing the material consumption for the product requirement. Every batch is consistent and to the desired formula. No "hunting" or statistical averaging to achieve the required target.

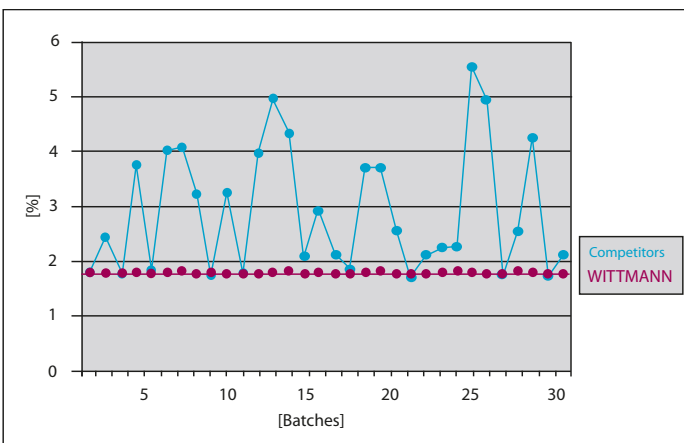

Where do the savings come from?

By ensuring batch-to-batch accuracy by means of RTLS (Real Time Live Scale) technology the operator can set the percentages to the required minimum level. As competitive blending methods are constantly overdosing and underdosing the minimum needs to be set to allow any underdosed batch to still be at the requested percentage.

This results in overdosing all other batches, sometimes even significantly, causing tremendous excess material usage. RTLS can pay for itself in just a couple of months!

In this example, a blend of 1.8% has been set. Real data demonstrates the difference between RTLS and other methods.

GRAVIMAX SERIES BLENDERS

Wittmann

GRAVIMAX BLENDER SERIES 1

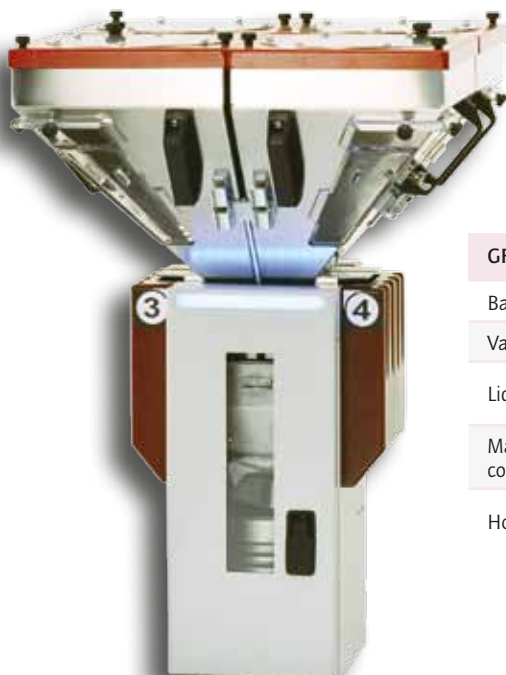

GRAVIMAX Series 1	
Batch size	1 kg (2.2 lbs.)
Valve	40 mm (1.6")
Lid prepared for	FEEDMAX 200 Series
Max. number of components	4
Hopper size 1-4	13 l (16.2 lbs.)

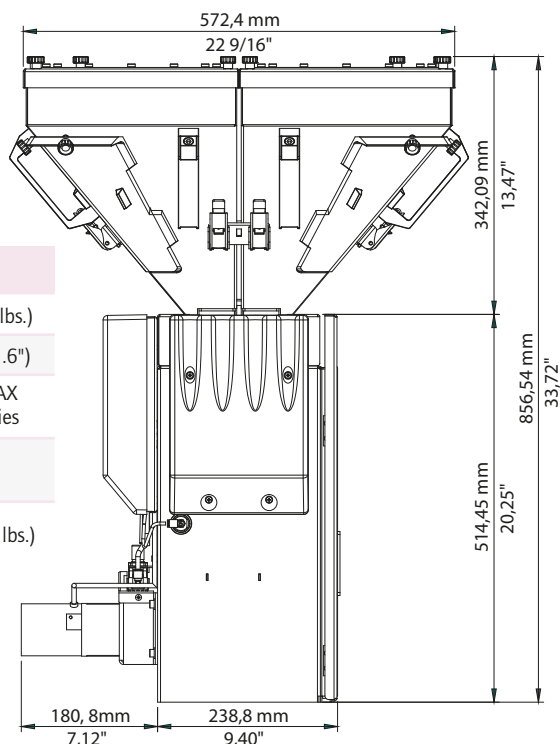

GRAVIMAX BLENDER SELECTION

Model	Description	Batch Size		Throughput*	
		kg	lbs.	kg/hr.	lbs./hr.
GMX G14	4 Materials	1	2.2	80	170
GMX G34	4 Materials	3	6.6	200	450
GMX G56	6 Materials	5	11	600	1,320
GMX 94	4 Materials	9	20	680	1,490
GMX 95	5 Materials	9	20	540	1,190
GMX 96	6 Materials	9	20	490	1,070
GMX 97	7 Materials	9	20	410	900
GMX 98	8 Materials	9	20	330	720
GMX 184	4 Materials	18	40	1,500	3,300

Model	Description	Batch Size		Throughput*	
		kg	lbs.	kg/hr.	lbs./hr.
GMX 185	5 Materials	18	40	1,200	2,640
GMX 186	6 Materials	18	40	1,060	2,340
GMX 187	7 Materials	18	40	950	2,100
GMX 188	8 Materials	18	40	900	1,980
GMX 274	4 Materials	27	60	1,770	3,900
GMX 275	5 Materials	27	60	1,560	3,420
GMX 276	6 Materials	27	60	1,500	3,300
GMX 277	7 Materials	27	60	1,440	3,180
GMX 278	8 Materials	27	60	1,380	3,060

* Average values; the actual throughput can vary, and is depending on the respective material.

GRAVIMAX SERIES BLENDERS

GRAVIMAX BLENDER SERIES 3



GRAVIMAX Series 3	
Batch size	3 kg (6.6 lbs.)
Valve	40 + 60 mm (1.6" + 2.4")
Lid prepared for	FEEDMAX 200 + 300 Series
Max. number of components	4
Hopper size 1-4	1 + 4: 13 l (16.5 lbs.) 2 + 3: 30 l (38 lbs.)

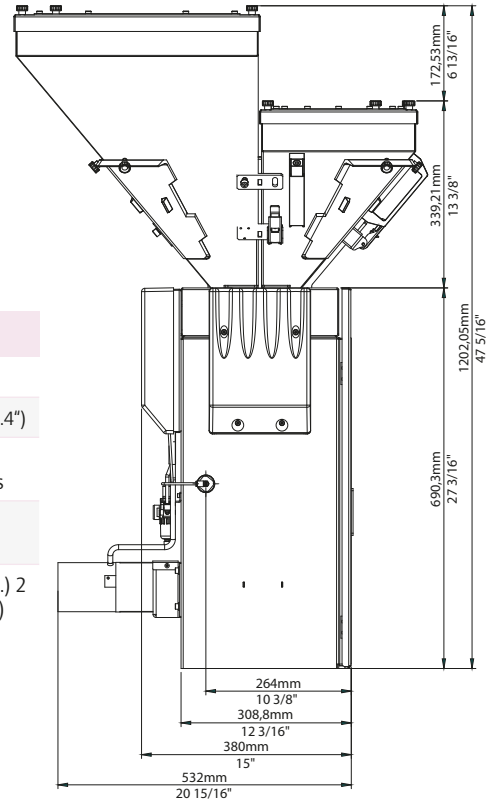

GRAVIMAX BLENDER SERIES 5



GRAVIMAX Series 5	
Batch size	5 kg (11 lbs.)
Valve	80 mm (3.2")
Lid prepared for	FEEDMAX 200 + 300 Series
Max. number of components	6
Hopper size 1-4	67 l (82 lbs.)
Hopper size 5-6	40 l (49 lbs.)

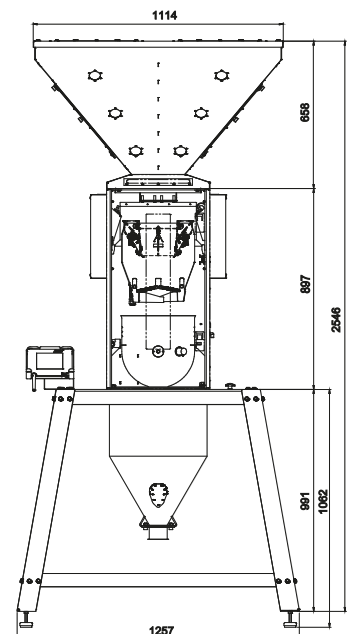

GRAVIMAX BLENDER SERIES 9

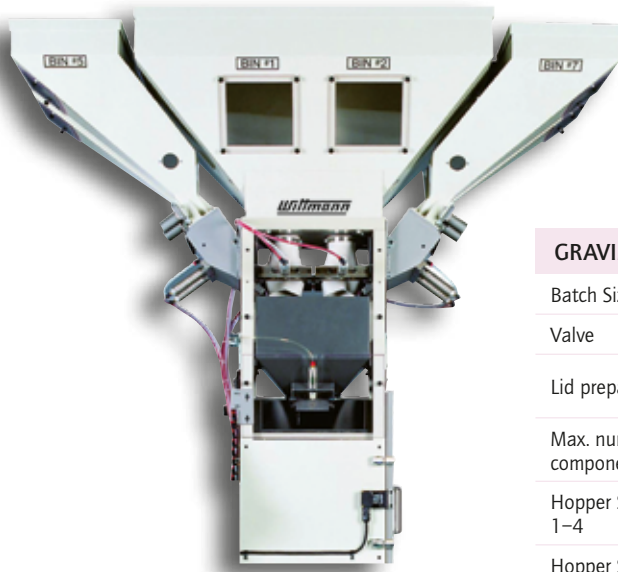

GRAVIMAX Series 9

Batch Size	9 kg (20 lbs.)
Valve	75 mm (3")
Lid prepared for	FEEDMAX 300 Series
Max. number of components	8
Hopper Size 1-4	79 l (100 lbs.)
Hopper Size 5-8	34 l (40 lbs.)

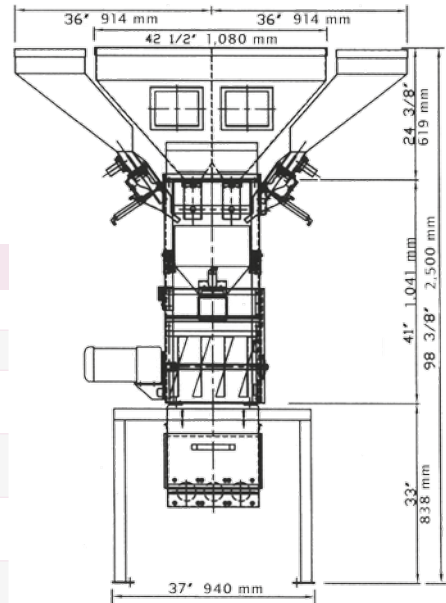

GRAVIMAX BLENDER SERIES 18 AND 27

Engineered Solutions for Maximum Throughput

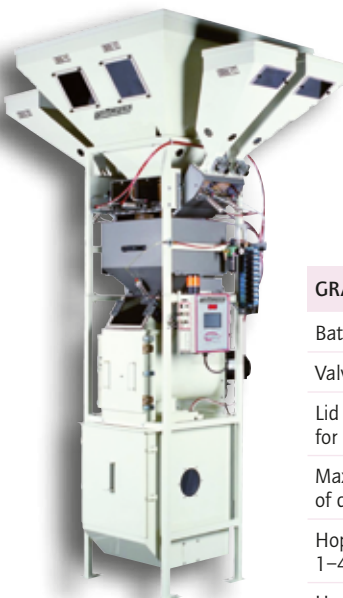

GRAVIMAX Series 18

Batch size	18 kg (40 lbs.)
Valve	100 mm (4")
Lid prepared for	FEEDMAX 400 Series
Max. number of comp.	8
Hopper size 1-4	147 l (180 lbs.)
Hopper size 5-8	34 l (40 lbs.)



GRAVIMAX Series 27

Batch size	27 kg (60 lbs.)
Valve	150 mm (6")
Lid prepared for	FEEDMAX 400 Series
Max. number of comp.	8
Hopper size 1-4	158 l (200 lbs.)
Hopper size 5-8	68 l (80 lbs.)

BLENDER CONTROL

GRAVIMAX CONTROL

Designed for Simplicity, Ease-of-Use and High Efficiency



The large easy-to-see buttons on the touch screen make it easy to operate in all types of light conditions and ensures the operator has a large surface area to make changes or adjustments in the operation of the blender.

High-capacity microprocessor controller



STANDARD FEATURES

- » **Control of up to 8 components**
- » **Dosing-technology**
Precise metering through adaptive control algorithms.
- » **RTLS (Real Time Live Scale) technology**
2-stage progressive metering method for the most precise target weight.
- » **"On the fly" feature**
Change recipes and parameters without stopping production.
- » **Reports**
Cycle, total run and inventory reports.
- » **Connectivity options (Ethernet)**
Compatible with central PCs, PDAs, laptops.
- » **"SmartRegrind" mode**
Automatic recipe adjustment, depending on the availability of the material.
- » **Mixing**
Timed or continuous.
- » **User interface**
The handling of the user interface is conform to the other WITTMANN manual control elements.
- » **Percent preset**
Each ingredient value can be entered in % or as ratio.
- » **Unit values**
Operates in metric or imperial.
- » **Display operating conditions**
Displays the recipe running, setpoint and actual values, process rate.
- » **Materials identification**
Alphanumeric key pad for clear material identification.
- » **Recipe maintenance**
500 recipes stored on the local memory.
- » **Preset batch count**
Automatic blender shutdown after reaching the preset batch count.
- » **Material bridging**
Special dosing algorithms are loosening bridge formations of material in the hoppers.
- » **Security**
3 adjustable security levels with freely selectable access codes.
- » **Reference additive**
Automatic adjustment of ratio to avoid an overdosing of expensive additives.
- » **Self-optimization**
Independent adjustment of the dosing behaviour to varying flow characteristics of different materials.
- » **Secure mounting of the load cells for most exact measurement and long-lasting use.**
- » **Control Panel with standard electrical components for reliable operation and easy maintenance.**
- » **Power supply**
110 V / 230 V / 1 / 50-60 Hz

GraviLog

GraviLog is the name of a software solution that has been especially developed for data recording of gravimetric blenders of the WITTMANN **GRAVIMAX G** series. This comprehensive software makes it easy to analyze various differing factors, for example the material consumption of several devices in regard to a special working process. And using **GraviLog** makes it possible to generate graphical representations for target and performance values.

- » **Software**
for up to 20 devices.
- » **Control of devices**
directly from a personal computer
- » **Administration**
of recipes and materials.
- » **Search functions:**
devices, materials, time.
- » **Graphic representation**
of material use and deviations.
- » **Export function**
for the export of tables.

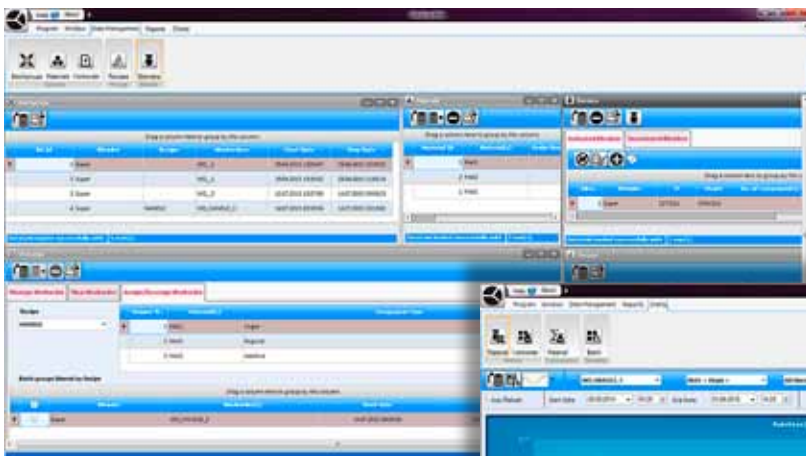

GraviLog
data and chart

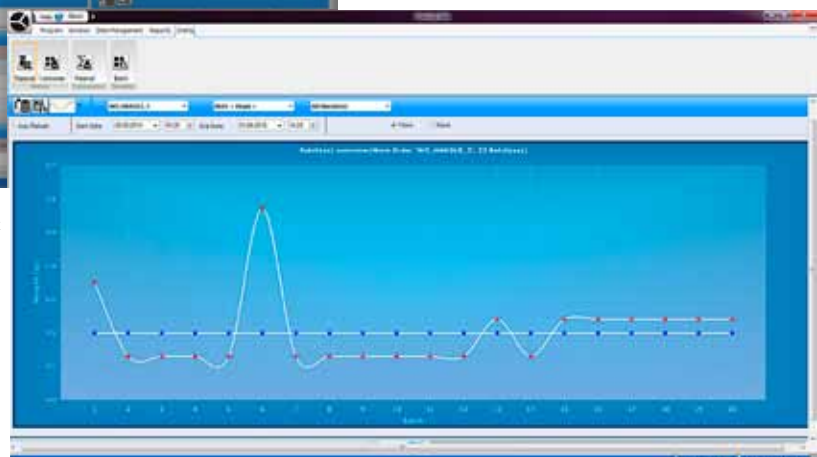

SEMI-GRAVIMETRIC DOSING SYSTEMS

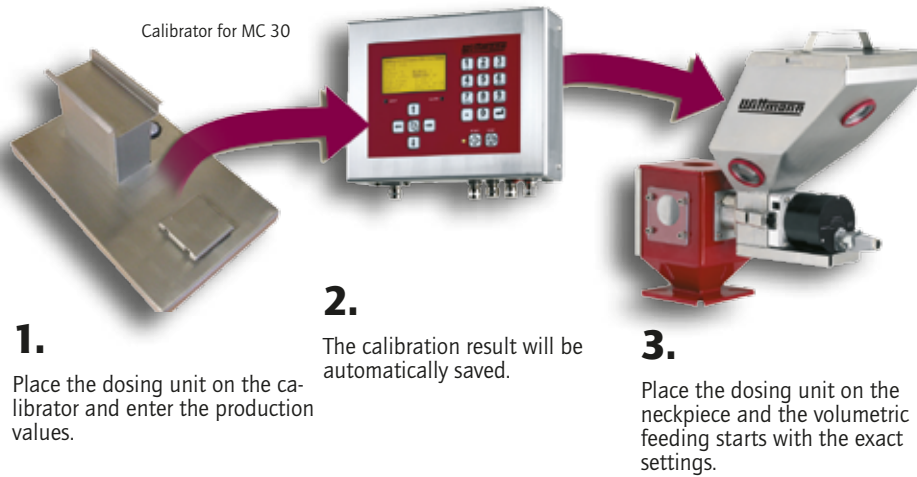

1.
Place the dosing unit on the calibrator and enter the production values.

2.
The calibration result will be automatically saved.

3.
Place the dosing unit on the neckpiece and the volumetric feeding starts with the exact settings.

DOSIMAX MC 30

- » Set % for injection molding and extrusion.
- » Timer and relay mode for injection molding applications.
- » Tachometer synchronization for extrusion applications.
- » Keyboard lock: 4 levels.
- » Integrated conveying control.
- » Data memory for production and machine configuration.
- » Graphic LCD display with backlight.
- » Man/machine interface via key-pad foil.
- » Neckpiece with cleaning door.
- » Quick material discharge slide gate.

DOSIMAX SELECTION TABLE

Function	MC basic	MC 12	MC 18 Calibrate	MC 30 Auto	MC balance
Feeding principle		volumetric		volumetric + optional gravimetric calibration	gravimetric loss-in-weight
Calibration		manual		gravimetric intelligent or manual	complete gravimetric or manual
Control functions					
Revolution set		manuell			automatic or manual
Time set		manuell			automatic or manual
Automatic dosing time synchronization			•	•	•
Extruder "tachometer" mode			•	•	•
Set % additive for injection molding				•	•
Set % additive for extrusion				•	•
Additive for calibration mode				•	•
Production memory				1500 configuration	
Production records				2 x 24 hours	
Interface communication via ethernet				•	•
Interface communication RS-232/485			◦	◦	◦
Keyboard lock		1 level			4 levels
Integrated conveying control			•	•	•
Material/Feeding capacity					
Micro granules or free flowing powder	•	•	•	•	•
BASIC-System 0.2 to 5 g/s	•				
GLX-System* 0.02 to 1.6 g/s	◦	◦	◦	◦	◦
GX-System* 0.2 to 5 g/s		•	•	•	•
A-20 System** 0.5 to 20 g/s			◦	◦	◦
A-30 System** 2 to 50 g/s			◦	◦	◦
• = standard; ◦ = optional; *determined with masterbatch granules (bulk density: 0.81 kg/dm ³); **only in combination with HT stepper motor					

DOSIMAX

Volumetric Dosing Systems

Wittmann

DOSING CYLINDER



Dosing Cylinder

Many applications for the processing of additives and colors require small and repeatable material additions within tight tolerances. The dosing cylinder guarantees a uniform and repeatable flow throughout a wide range of applications.

Because of the constant speed of rotation, the dosing cylinder is actuated by a stepping motor. The specific design guarantees that the master batch is blended uniformly and precisely. The avoidance of any pulsing during blending provides maximum control of the process and the end product.

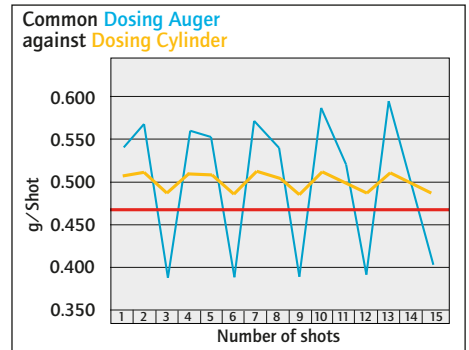

DOSIMAX MC basic

Technical features

- » Digital revolution setting from 0 to 200 rpm within 0.1 rpm steps.
- » Digital time setting from 0 to 999 sec. within 0.1 sec. steps.
- » Timer mode for injection molding applications.
- » Keyboard lock: 1 level.
- » 4-digit, 7 segment LED at front display.
- » Man/machine interface via keypad foil.



MC Basic



MC Basic Control

DOSIMAX MC 12 and MC 18

Technical features

- » Digital revolution setting from 0 to 200 rpm within 0.1 rpm steps.
- » Digital time setting from 0 to 999 sec. within 0.1 sec. steps.
- » Keyboard lock: 1 level.
- » 4-digit, 7-segment LED at front display.
- » Man/machine interface via keypad foil.
- » Neckpiece with cleaning door.
- » Quick material discharge slide gate.



MC 12/18

MC 12/18 Control



MC 12 additional function

- » Timer and relay mode for injection molding applications.

MC 18 additional functions

- » Tachometer synchronization for extrusion applications.
- » Constant dispensing through automatic adjustment of rotation speed.
- » Integrated conveying control.

The Wittmann logo is a stylized, italicized wordmark in a dark red color, set against a white background that is part of a red parallelogram shape.

WITTMANN Kunststoffgeräte GmbH

Lichtblaustrasse 10

1220 Vienna | Austria

Tel.: +43 1 250 39-0 | Fax: +43 1 259 71 70

info.at@wittmann-group.com

www.wittmann-group.com