

**gama 7x**

P  
L  
A  
S  
T  
I  
C  
S

- Panoramica prodotti 🇮🇹
- Products overview 🇬🇧
- Produktübersicht 🇩🇪
- Gamme de produits 🇫🇷
- Gama de productos 🇪🇸
- Gama de produtos 🇵🇹
- Charakterystyka produktów 🇵🇱
- Ürünler 🇹🇷
- 产品概述 🇨🇳
- 製品一覧表 🇯🇵
- 제품 개요 🇰🇷

## Distributors of Plastics products

30/09/2016

**GIMATIC**  
Group

### CONSOCIATE ITALIANE

*Piemonte, Liguria, Valle D'Aosta, Como, Lecco, Milano, Monza e Brianza, Pavia, Varese, Lodi, Verbania, Campania, Lazio, Puglia, Basilicata, Calabria Sicilia, Sardegna*  
**GIMATRADE S.r.l.**  
Via Borgomanero, 1  
28010 Veruno (NO)  
Tel. +39 0322 830624  
Fax +39 0322 830624  
info@gimatrade.it  
www.gimatrade.it

*Bergamo, Brescia, Cremona, Mantova, Sondrio*  
*Bolzano, Trento*  
*Verona*  
*Piacenza, Parma, Reggio Emilia Toscana*

### **GIMATRADE BRESCIA S.r.l.**

Via Chiusure, 5/b  
25127 Brescia (BS)  
Tel. +39 030 320212  
Fax +39 030 2415436  
info@gimatradebrescia.it  
www.gimatradebrescia.it

*Padova, Rovigo, Vicenza*  
*Modena, Bologna, Ferrara, Ravenna, Forlì e Cesena, Rimini*  
**GIMATRADE VICENZA S.r.l.**  
Piazzetta Aldo Moro, 12  
35035 Mestrino (PD)  
Tel. +39 049 9004613  
Fax +39 049 9004613  
info@gimatradevicenza.it  
www.gimatradevicenza.it

*Belluno, Treviso, Pordenone, Venezia, Udine, Trieste, Gorizia*  
**GIMATRADE TREVISO S.r.l.**  
Via Giovanni Verga, 21  
33082 Corva di Azzano (PN)  
Tel. +39 0434 646156  
Fax +39 0434 646156  
info@gimatradetreviso.it  
www.gimatradetreviso.it

**GIMATIC**  
Group

### FOREIGN SUBSIDIARIES

*Germany*  
**GIMATIC VERTRIEB GmbH**  
Linsenäcker 18  
72379 Hechingen  
Ph. +49 7471 96015 - 0  
Fax +49 7471 96015 - 19  
zentrale@gimaticvertrieb.de  
www.gimaticvertrieb.de

*Spain*  
**GIMATIC SPAIN S.I.**  
C/Corín Tellado n° 8 - 1ª A  
33204 Gijón - Asturias - ESPAÑA  
Ph. +34 984 493 897  
Fax +34 984 493 897  
jrodriguez@gimaticspain.es  
www.gimaticspain.com

*France*  
**EURL GIMATIC FRANCE**  
265 rue Denis Papin  
38090 Villefontaine - FR  
Ph. +33 768 380 865  
vbecart@gimatic.fr  
www.gimatic.fr

*Denmark, Iceland, Estonia, Lithuania, Latvia, Finland, Sweden, Norway*  
**GIMATIC NORDIC AB**  
Oestergarden 114  
18637 Vallentuna - SE  
Ph. +46 (8) 121 445 00  
Fax +46 (0) 8 120 503 70  
nordic@gimatic.se  
www.gimatic.com

*Czech Republic, Slovakia*  
**GIMATIC CZECH REPUBLIC, s.r.o.**  
Pod Hájem 290  
250 73, Přezletice  
Ph. +420 608 954 500  
Fax +420 222 364 605  
info@gimatic.cz  
www.gimatic.cz

*Poland*  
**GIMATIC POLSKA Sp. z o.o.**  
Okulickiego 23b/58  
42-200 Częstochowa  
Ph. +48 34 38 73 052  
Fax +48 34 38 73 051  
gimatic@gimaticpolska.pl  
www.gimaticpolska.pl

*Turkey*  
**GIMATIC OTOMASYON TICARET LTD. STI.**  
Perpa Tic. Merk. A Blok Kat:11  
No:1478  
34160 Okmeydani, Istanbul  
Ph. +90 212 210 83 91  
Fax +90 212 210 83 98  
gimatic@gimatic.com.tr  
www.gimatic.com.tr

*China, Hong Kong, Macao, Taiwan*  
**GIMATIC AUTOMATION TECHNOLOGY (SHANGHAI) CO. LTD**  
Room 805, Block 8-9,  
Lane 1500 South Lianhua Road  
201108 Shanghai - CN  
Ph. (+86) 021 54735580  
Fax (+86) 021 54735680  
info@gimatic-china.com  
www.gimatic.com

*South Korea*  
**GIMATIC KOREA Limited**  
RN 215 27 Sankidaehak-ro  
Siheung-si, Gyeonggi-do, Korea  
(Jeongwang-dong, Rasung Venture Town)  
Ph. +82 31 504 8771  
Fax +82 31 504 8772  
sales@gimatic.co.kr  
www.gimatic.co.kr

*Central and Latin America*  
**GIMATIC AUTOMAÇÃO Ltda**  
Rua Campos Salles, 190  
09551-310 Bairro Barcelona  
São Caetano do Sul  
São Paulo - BRASIL  
Ph. +55 11 4318 2550  
Fax +55 11 4318 2551  
gimatic@gimatic.com.br  
www.gimatic.com.br

*U.S.A., Canada, Mexico*  
**GIMATIC USA**  
28300 Euclid Ave.  
44092 Wickliffe, Ohio - USA  
Ph. +1 216 535 4811  
Fax +1 216 535 4833  
sales@gimaticusa.com  
www.gimaticusa.com

*Japan*  
**GIMATIC JAPAN**  
3-3-15-702, Azabudai,  
Minato-Ku - Tokyo, 106-0041  
Ph. +81 (0)3 6322 5816  
Fax +81 (0)3 6800 2770  
info@gimatic.co.jp  
www.gimatic.co.jp

### ITALIA

*Ancona, Pesaro Urbino, Macerata*  
**A.T.I. S.r.l. ARTICOLI TECNICI INDUSTRIALI**  
Via Bruno Buoizzi, 8  
60044 Fabriano (AN)  
Tel. +39 0732 639 111  
Fax +39 0732 626 641  
vendite@ati-srl.com  
www.ati-srl.com

*Abruzzo, Ascoli Piceno, Fermo, Macerata*  
**TKF S.r.l.**  
Via Dei Castani  
64014 Martinsicuro (TE)  
Tel. +39 0861 762 092  
Fax +39 0861 797 942  
acquisti@tkf srl.com

## EUROPE

### *Austria*

**BRUTECS GmbH**  
Groß-Dörnbach Straße, 12  
A-4073 Wilhering  
Ph. +43 664 380 6747  
Fax +43 7221 87093  
office@bruteacs.com  
www.bruteacs.com

### *Switzerland*

**ROBXPPTS GmbH**  
Aachstrasse 2  
9326 Horn - SWITZERLAND  
Ph. +41 62 822 33 77  
mail@robxperts.com  
www.robxperts.com

### **ROBOCOM AG**

IM KELLERSFELD 21  
9491 - RUGGEL - LI  
Ph. +423 217 1369  
sfontana@robocom.liv  
www.robocom.li

### *United Kingdom*

**GEIGER HANDLING UK Ltd**  
Raleigh Hall Industrial Estate -  
Eccleshall  
ST21 6JL Stafford ENGLAND  
Ph. +44 178 585 1111  
Fax +44 178 585 9090  
sales@geigerhandling.co.uk  
www.gimatic.co.uk

### *Belgium, Luxembourg*

**CS PLASTICS bvba**  
Spieveldstraat 14  
9160 Lokeren - BELGIUM  
Ph. +32 9 262 04 60  
Fax +32 (0)9 356 00 15  
info@csplastics.be  
www.csplastics.be

### *Portugal*

**DELTAPLAS Lda**  
Zona Industrial da Barosa -  
Petigais  
2400-013 Leiria - PORTUGAL  
Ph. +35 1244 823 217  
Fax +35 1244 823 218  
deltapls-leiria@mail.telepac.pt

### *Greece*

**TECNOPNEUMATIC A.E.**  
97, Iera Odos Str.  
11855 Athens - GRECIA  
Ph. +30 210 346 70 00  
Fax +30 210 347 99 30  
avieris@tecnopneumatic.gr  
www.tecnopneumatic.gr

### *Bulgaria*

**MASTER Ltd**  
26 Tsar Asen Str.  
7000 Ruse - BULGARIA  
Ph. +35 982 836 530  
Fax +35 982 826 530  
ruse@master-bg.com  
www.master-bg.com

### *Serbia, Slovenia, Croatia*

**KOVIMEX**  
Podskranik 60  
1380 Cerknica - SLOVENIA  
Ph. +386 (170) 96 430  
Fax +386 (402) 18 211  
kovimex@kovimex.si  
www.kovimex.si

### *Hungary*

**GRIP-PLAST Kft.**  
HUNGARY  
lkva u.7  
H-8000 Székesfehérvár  
Mobil +36 302 093 773  
Ph. +36 227 883 90  
Fax +36 227 883 90  
a.jobbagy@grip-plast.hu

## ASIA

### *India*

**NEEJTECH India**  
305, Swagat Building C.G. Road,  
Ahmedabad  
380009 - GUJARAT - IN  
Ph. +91 98250 40231  
Fax +91 79265 61312  
info@neejtech.com  
www.neejtech.com

### *Indonesia, Malesia, Thailand*

**ROBOMATION EQUIPMENT SDN BHD**  
N.13A, Jalan Kenari 17D  
Bandar Puchong Jaya  
47170 - Puchong, Selangor,  
MALAYSIA - MY  
Ph. +60 380 750 833  
Fax +60 380 600 666  
osprecisions@gmail.com

### *Thailand*

**FUTURE STATE (Asia) Co. Ltd.**  
86/1 Soi Thianthalay, 22  
Bangkhunthian  
Thakham, Bangkhunthian  
10150 Bangkok Thailand  
Ph. +66 25 30 04 05  
Fax +66 25 30 04 06  
nianinbkk@hotmail.com  
www.futurestateasia.com

### *Israele*

**R.E.P. Automation Ltd**  
2, HaAmelim St. P.O.B.  
10115, Haifa Bay 26110  
ISRAELE  
Ph. +97 248 403012  
Fax +97 248 403013  
rep@repac.co.il  
www.repac.co.il

### *Russia*

**IBC SYSTEMS**  
Kuskovskaya str.20A, off.611A  
111141 Moscow - RUSSIA  
Ph. +74 957 270 528  
Fax +74 957 270 529  
info@ibcplastic.ru  
www.ibcplastic.ru

## AFRICA

### *South Africa*

**PLASTIC & CHEMICAL TRADING**  
P.O BOX 92223 Norwood  
2117 - SOUTH AFRICA  
Ph. +27 11 483 3015  
Fax +27 11 728 3419  
matt@plastrading.com

## AMERICA

### *Argentina*

**GENERAL AUTOMATION Srl**  
ALVEAR, 360  
1619 GARIN (BUENOS AIRES)  
Ph. +54 (0) 348 462 4481  
am@ga-srl.com.ar  
www.ga-srl.com.ar

### *Chile, Peru*

**EQUIPAMIENTO Y AUTOMATIZACION PROAPSIS Spa**  
Las Calizas, 58  
Cond. Los Portones Colina  
9340000 Santiago - CL  
Ph. +56998282612  
jvasquez@proapsis.cl

## OCEANIA

### *Australia*

**ENKOSI PTY LTD**  
Unit 3/9 Nicole Close  
3153 Bayswater noth vic  
AUSTRALIA  
Ph. +61 397 616 377  
Fax +61 397 616 499  
graham@enkosi.com.au  
www.enkosi.com.au

Moduli di fissaggio  
 Modular clamping system  
 Klemmstücke  
 Modules de fixation  
 Módulos de fijación  
 Módulos de fixação  
 System mocowania modułowego  
 Modüler bağlantı sistemi  
 模块化紧固系统  
 モジュラー・クランピングシステム  
 모듈형 클램프 시스템

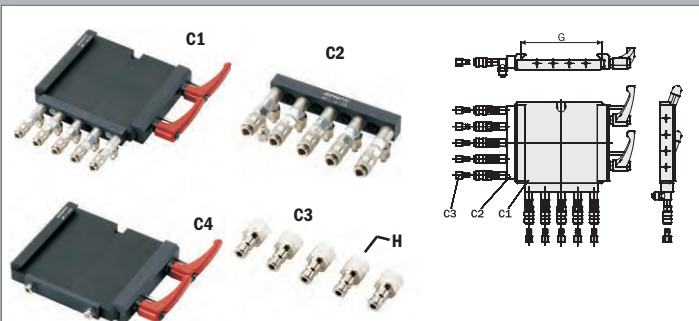

Cambia utensile (lato robot) / Quick changer (robot side) / Schnellwerkzeugwechsler (Robotseite) / Changeur d'outil rapide (Côté robot) / Cambio rápido (lado robot) / Mudança rápida (lado do robot) / System szybkiego zmieniania (po stronie robota) / Çabuk değiştirici (robot tarafı) / 快速转换模块 (机械手侧) / ツールチェンジャー (ロボット側) / 킷 체인저 (로봇쪽)

		G [mm]	H	m [g]	N°
MFI-A130	C1	100		620	
MFI-A131	C1	160		1650	
MFI-A133	C2			140	
MFI-A132	C2			450	
MFI-A135	C3		M5	17	(x5)
MFI-A134	C3		G1/8	40	(x5)
MFI-A40	C4			500	
MFI-A42	C4			1270	
MFI-A343E	<b>NEW</b>			165	

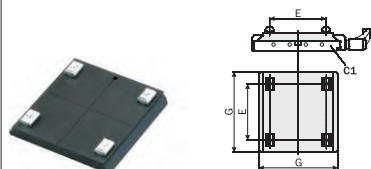

Cambia utensile (lato pinza) / Quick changer (grripper side) / Schnellwerkzeugwechsler (Greiferseite) / Changeur d'outil rapide (Côté pince) / Cambio rápido (lado garra) / Mudança rápida (lado da mão de presa) / System szybkiego zmieniania (po stronie chwytaka) / Çabuk değiştirici (tutucu tarafı) / 快速转换模块 (治具侧) / ツールチェンジャー (グリッパー側) / 킷 체인저 (그리퍼쪽)

	E [mm]	G [mm]	m [g]
MFI-A41	70	100	270
MFI-A43	120	160	670
MFI-A344	<b>NEW</b>	40	60



Magazzino per EOAT / EOAT Storage / Lagerung EOAT / Dépôt pour main de préhension / Soporte para almacenamiento de la EOAT / Suporte para EOAT / Zasobnik EOAT / Robot eli askı aparatı / 治具存放架 / チャック固定用・治具 / EOAT 스토리지

		m [g]
MFI-A344-H	<b>NEW</b>	143
MFI-A41-H	<b>NEW</b>	250
MFI-A43-H	<b>NEW</b>	575



Profili estrusi / Extruded profiles / Alu profiles / Profilé-filé / Perfiles de extrusión / Perfis extrudidos / Profile ekstrudowane / Çekme Profiller / 型材 / 押出材プロファイル / 압출 프로파일

	L [m]	m [g]
EMB-2017-1000	1	340
EMB-2017-2000	2	680
EMB-3026-1000	1	700
EMB-3026-2000	2	1400
EMB-5045-1000	1	1665
EMB-5045-2000	2	3330

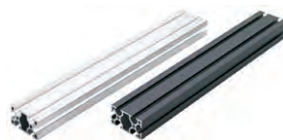

Profili estrusi / Extruded profiles / Alu profiles / Profilé-filé / Perfiles de extrusión / Perfis extrudidos / Profile ekstrudowane / Çekme Profiller / 型材 / 押出材プロファイル / 압출 프로파일

	L [m]	m [g]
EMB-1018-1000	1	250
EMB-1018-2000	2	500
EMB-1818-1000	1	380
EMB-1818-2000	2	760
EMB-2510-1000	1	280
EMB-2510-2000	2	560
EMB-2518-1000	1	400
EMB-2518-2000	2	800
EMB-2525-1000	1	610
EMB-2525-2000	2	1220
EMB-5025-1000	1	1040
EMB-5025-2000	2	2080
EMB-4040-1000	1	1300
EMB-4040-2000	2	2600
EMB-8040-1000	1	2180
EMB-8040-2000	2	4360



Tubi in carbonio / Carbon tubes / Rohre aus Kohlenstofffaser / Tubes en carbone / Tubos de carbono / Tubos de carbono / Rury węglowe / Karbon borular / 碳管 / カーボンファイバー製チューブ / 카본 튜브

	L [m]	m [g]
TFC-2017-1000	<b>NEW</b>	130
TFC-2017-1500		195
TFC-2017-2000	<b>NEW</b>	260
TFC-3026-1000	<b>NEW</b>	260
TFC-3026-1500		390
TFC-3026-2000	<b>NEW</b>	520

Moduli di fissaggio  
 Modular clamping system  
 Klemmstücke  
 Modules de fixation  
 Módulos de fijación  
 Módulos de fixação  
 System mocowania modułowego  
 Modüler bağlantı sistemi  
 模块化紧固系统  
 모듈러·클램핑시스템  
 모듈형 클램프 시스템



Profili estrusi / Extruded profiles / Alu profiles / Profilé-filé / Perfiles de extrusión /  
 Perfis extrudados / Profile ekstrudowane / Çekme Profiller / 型材 / 押出材プロファイル  
 / 압출 프로파일

	L [m]	m [g]
<b>MF-20-1000</b>	1	230
<b>MF-20-2000</b> <b>NEW</b>	2	460
<b>MF-30-1000</b>	1	444
<b>MF-30-2000</b> <b>NEW</b>	2	888



Tappi / Plugs / Verschluss / Bouchon / Tapones / Tampas / Zatyczka / Profil kapağı /  
 端盖 / 프로파일용プラグ / 플러그

<b>MFI-A21</b>	EMB-2525, EMF-2525	(1)
<b>MFI-A22</b>	EMB-5025, EMF-5025	(1)
<b>MFI-A23</b>	EMB-1818, EMF-1818	(1)
<b>MFI-A24</b>	EMB-1018, EMF-1018	(1)
<b>MFI-A25</b>	EMB-4040, EMF-4040	(1)
<b>MFI-A26</b>	EMB-8040, EMF-8040	(1)
<b>MFI-A27</b>	EMB-2510, EMF-2510	(1)
<b>MFI-A28</b>	EMB-2518, EMF-2518	(1)
<b>MFP-K21</b>	MF-30, TFC-30	(1)
<b>MFP-K22</b>	MF-20, TFC-20	(1)
<b>MFP-K28</b>	EMB-3026	(1)
<b>MFP-K29</b>	EMB-2017	(1)
<b>MFP-K50</b>	EMB-5045	(1)

(1)  
 Confezione da 10 pezzi / 10 pieces package / 10 Stück Packung / Vendu par 10 pièces  
 / Paquete de 10 piezas / Embalagem de 10 peças / 10 sztuk w opakowaniu / Her  
 paket 10 Adettir / 10个一包 / 一袋10個入 / 10피스 패키지

(4)  
 Dado last-minute / Last-minute nut / Last-minute Mutter / Écrou dernière minute /  
 Tuerca último minuto / Porca ultimo minuto / Nakrętka „w ostatniej chwili” / Son dakika  
 somunu / 附加螺母 / 追加用·ナット / 라스트미닛 너트

(7)  
 Dado a molla / Spring nut / Federmutter / Écrou à ressort / Tuerca de muelle / Porca  
 com mola / Nakrętka sprężysta / Yaylı somun / 彈簧螺母 / 스프링나ット / 스프링  
 너트

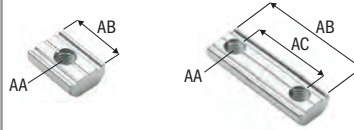

Dadi / T-Nuts / Mutter / Écrous / Tuercas / Porcas em T / Nakrętki kłowe / Somunlar /  
 螺母 / T型·ナット / T-너트

	AA	AB [mm]	AC [mm]	m [g]
<b>MFI-177</b>	M4	15		5
<b>MFI-025</b>	M5	15		5
<b>MFI-178</b>	M6	15		5
<b>MFI-003</b>	M4	16	8	5
<b>MFI-006</b>	M5	20	10	7
<b>MFI-009</b>	M5	25	15	9
<b>MFI-148</b>	M5	25	17	9
<b>MFI-016</b>	M5	32	22	11
<b>MFI-027</b>	M5	35	25	13
<b>MFI-055</b>	M5	38	28	14
<b>MFI-050</b>	M5	40	30	15
<b>MFI-029</b>	M5	45	35	16
<b>MFI-020</b>	M5	50	40	18
<b>MFI-043</b>	M5	60	50	22
<b>MFI-022</b>	M5	70	60	26
<b>MFI-045</b>	M5	100	90	38
<b>MFI-243</b>				2 (4)
<b>MFI-A329</b>	M4	15		5 (7)
<b>MFI-A331</b>	M5	15		5 (7)



Interfaccia tubi con QC...-B / Interface between tubes and QC...-B / Schnittstelle für  
 Profilrohre zur Befestigung an QC...-B / Interface tubes avec QC...-B / Interfaz para  
 tubos y QC...-B / Interface entre tubos e QC...-B / Łącznik rury i szybkozłącza QC...-B /  
 Arayüz (QC...-B - boru\profil arasinda) / 管子与QC...-B之间的接口 / QC-B用·チューブ  
 固定用インターフェース / 튜브와 QC...-B 사이의 인터페이스

	m [g]
<b>MFI-A313</b>	Ø30 744
<b>MFI-A328</b>	Ø20 322



Interfaccia / Interface / Schnittstelle / Interface / Interfaz / Interface / Interfejs / Arayüz  
 / 界面 / QC-B用·プロファイル固定用インターフェース / 인터페이스

	m [g]
<b>MFI-A277</b>	QC50-B 90
<b>MFI-A102</b>	QC90-B 160
<b>MFI-A103</b>	QC150-B / QC160-B 490
<b>MFI-A276</b>	QC200-B 1300

Moduli di fissaggio  
 Modular clamping system  
 Klemmstücke  
 Modules de fixation  
 Módulos de fijación  
 Módulos de fixação  
 System mocowania modułowego  
 Modüler bağlantı sistemi  
 模块化紧固系统  
 モジュラー・クランピングシステム  
 모듈형 클램프 시스템



Staffa in acciaio inox per fissaggio a 90° di profili / Stainless steel angle bracket for profiles / Winkelverbinder 90° aus Edelstahl für Profile / Bride à angle droit en acier inox pour fixation / Escuadra para la unión de perfiles / Suporte com ângulo 90° para fixação dos perfis / Uchwyt kątowy ze stali nierdzewnej dla profili / Profiller için paslanmaz çelik köşe bağlantı braketi / 不锈钢制的型材角支架 / プロファイル固定用・90度ステンレスブラケット / 프로파일용 스테인리스강 앵글 브라켓

		m
		[g]
<b>MFI-A140</b>	24x24 mm	33
<b>MFI-A141</b>	49x49 mm	82

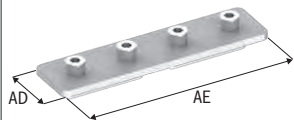

Piastra di fissaggio dritta / Straight fixing plate / Gerade Befestigungsplatte / Plaque de fixation droite / Placa de fijación directa / Placa de fixação direita / Łącznik prosty / Düz bağlantı braketi / 直的固定板 / プロファイル固定用・ストレートプレート / 직선 고정용 플레이트

	AD	AE	m
	[mm]	[mm]	[g]
<b>MFI-A226</b>	25	50	45
<b>MFI-A227</b>	25	100	95
<b>MFI-A228</b>	40	160	195

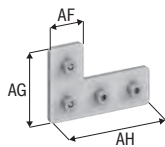

Piastra di fissaggio a L / L-shaped fixing plate / L-förmige Befestigungsplatte / Plaque de fixation en L / Placa de fijación en L / Placa de fixação em L / Łącznik L / L bağlantı braketi / L型固定板 / プロファイル固定用・L型プレート / L-형 고정용 플레이트

	AF	AG	AH	m
	[mm]	[mm]	[mm]	[g]
<b>MFI-A232</b>	25	50	50	70
<b>MFI-A233</b>	25	50	75	95
<b>MFI-A234</b>	40	80	120	200

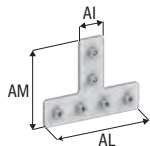

Piastra di fissaggio dritta / Straight fixing plate / T-förmige Befestigungsplatte / Plaque de fixation en T / Placa de fijación en T / Placa de fixação em T / Łącznik prosty / T bağlantı braketi / T型固定板 / プロファイル固定用・T型プレート / 직선 고정용 플레이트

	AI	AL	AM	m
	[mm]	[mm]	[mm]	[g]
<b>MFI-A229</b>	25	50	75	95
<b>MFI-A230</b>	25	100	75	145
<b>MFI-A231</b>	40	120	110	250



Piastra di fissaggio a 45° / 45° fixing plate / 45-Grad-Befestigungsplatte / Plaque de fixation à 45° / Placa de fijación a 45° / Placa de fixação a 45° / Łącznik 45° / 45° bağlantı braketi / 45度固定板 / プロファイル固定用・45度プレート / 45° 고정용 플레이트

	m
	[g]
<b>MFI-A221</b>	100

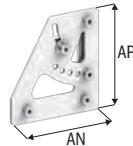

Piastra di fissaggio con angolo regolabile / Fixing plate with adjustable angle / Befestigungsplatte mit einstellbarem Winkel / Plaque de fixation à angle réglable / Placa de fijación con ángulo regulable / Placa de fixação com ângulo regulável / Łącznik z regulowanym kątem / Açı ayarlanabilir bağlantı braketi / 角度可調的固定板 / プロファイル固定用・角度調整プレート / 각도 조절이 가능한 고정용 플레이트

	AN	AP	m
	[mm]	[mm]	[g]
<b>MFI-A222</b>	60	85	130
<b>MFI-A223</b>	90	95	215
<b>MFI-A224</b>	70	100	175

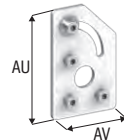

Piastra di fissaggio con angolo regolabile / Fixing plate with adjustable angle / Befestigungsplatte mit einstellbarem Winkel / Plaque de fixation à angle réglable / Placa de fijación con ángulo regulable / Placa de fixação com ângulo regulável / Łącznik z regulowanym kątem / Açı ayarlanabilir bağlantı plakası / 角度可調的固定板 / プロファイル固定用・角度調整プレート / 각도 조절이 가능한 고정용 플레이트

	AU	AV	m
	[mm]	[mm]	[g]
<b>MFI-A225</b>	80	50	115

**Moduli di fissaggio**  
**Modular clamping system**  
**Klemmstücke**  
**Modules de fixation**  
**Módulos de fijación**  
**Módulos de fixação**  
**System mocowania modułowego**  
**Modüler bağlantı sistemi**  
**模块化紧固系统**  
**モジュラー・クランピングシステム**  
**모듈형 클램프 시스템**

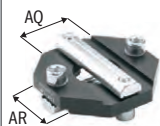

Piastra per fissaggio a croce di profili / Cross mounting bracket for profiles / Kreuzplatte für Profile / Bride pour fixation à croix de profiles / Placa para la unión de perfiles en cruz / Suporte para fixação em cruz dos perfis / Łącznik krzyżowy do profili / Profiller için çapraz montaj braketi / 固定型材的交叉安装支架 / プロファイル固定用・取付ブラケット (交差・溝固定) / 프로파일용 교차 설치식 브라켓

	AQ [mm]	AR [mm]	m [g]
MFI-A175	18	18	40
MFI-A265	18	25	60
MFI-A11	25	25	75
MFI-A12	50	50	170
MFI-A13	25	50	155
MFI-A29	40	40	85
MFI-A30	80	80	255
MFI-A31	40	80	175
MFI-A32	25	80	140
MFI-A33	25	40	75

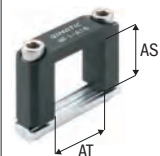

Staffa (quadra) per fissaggio a croce / Cross (square) joint connector / Kreuzverbinder (quadratisch) / Bride (carrée) pour fixation à croix / Abrazadera (cuadrada) para la fijación en cruz / Suporte (quadrado) para fixação em cruz / Uchwyt krzyżowy (kątowy) / Kare montaj braketi / 交叉 (方形) 连接器 / 角型プロファイル固定用・取付ブラケット (交差・外周固定) / 교차 조인트 커넥터 (사각형)

	AS [mm]	AT [mm]	m [g]
MFI-A244	18	18	32
MFI-A16	25	25	45
MFI-A17	50	25	65
MFI-A18	25	50	50



Staffa (tonda) per fissaggio a croce / Cross (round) joint connector / Kreuzverbinder (rund) / Bride (ronde) pour fixation à croix / Abrazadera (redonda) para la fijación en cruz / Suporte (redondo) para fixação em cruz / Uchwyt krzyżowy (okrągły) / Köprü montaj braketi / 交叉 (圓形) 连接器 / 丸型プロファイル固定用・取付ブラケット (交差・外周固定) / 교차 조인트 커넥터 (원형)

	BA [mm]	m [g]
MFI-A156	Ø10	15
MFI-A37	Ø14	32
MFI-A38	Ø20	45
MFI-A39	Ø30	75
MFI-A178	Ø50	150

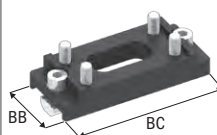

Fissaggio verticale profili / Vertical fastening of the profiles / Senkrechte Befestigung der Profile / Fixage verticale des profils / Brida de fijación vertical / Fixação vertical dos perfis / Uchwyt do pionowego mocowania profili / Profil dikey bağlantısı / 型材的垂直紧固件 / 角型プロファイル固定用・垂直取付ブラケット / 프로파일에 대한 수직 잠금장치

	BB [mm]	BC [mm]	m [g]
MFI-A217	30	50	65
MFI-A218	30	70	85
MFI-A219	55	50	110
MFI-A220	55	75	140



Interfaccia per braccio a sbalzo / Interface for square profile / Schnittstelle für Kragarm / Interface pour bras en porte-à-faux / Interface para brazo en voladizo / Interface para encastrar perfil / Złącze dla wysięgnika / Kare profiler için arayüz / 方形型材的接触面 / QC-B用・角型プロファイル垂直取付ブラケット / 원형 프로파일에 대한 인터페이스

	m [g]
MFI-A254	680
MFI-A255	1300

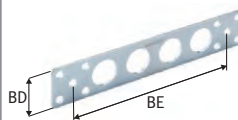

Connettore piatto dritto / Flat straight connector / Endplatte / Connecteur plat droit / Conector plano recto / Conector plano direito / Łącznik płaski prosty / Profil paralel birleştiricisi / 平直连接器 / 角型プロファイル固定用・ストレートプレート / 플랫폼 스트레이트 커넥터

	BD [mm]	BE [mm]	m [g]
MFI-A101	25	76	50
MFI-A19	25	120	60
MFI-A201	25	130	65
MFI-A100	50	76	75
MFI-A20	50	120	100
MFI-A202	50	130	110

Moduli di fissaggio  
 Modular clamping system  
 Klemmstücke  
 Modules de fixation  
 Módulos de fijación  
 Módulos de fixação  
 System mocowania modułowego  
 Modüler bağlantı sistemi  
 模块化紧固系统  
 モジュラー・クランピングシステム  
 모듈형 클램프 시스템

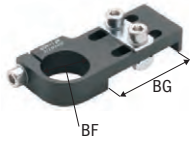

Staffa / Mounting bracket / Winkelklemmstück / Bride de fixation / Unión de montaje / Suporte de fixação / Uchwyt montażowy / Montaj braketi / 固定支架 / 取付ブラケット / 장착 브라켓

	BF [mm]	BG [mm]	m [g]
MFI-A01	Ø10	18	20
MFI-A270	Ø10	25	23
MFI-A02	Ø14	25	34
MFI-A204	Ø20	25	45
MFI-A03	Ø20	40	48

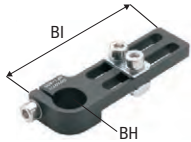

Staffa / Mounting bracket / Winkelklemmstück / Bride de fixation / Unión de montaje / Suporte de fixação / Uchwyt montażowy / Montaj braketi / 固定支架 / 取付ブラケット / 장착 브라켓

	BH [mm]	BI [mm]	m [g]
MFI-A04	Ø10	70	23
MFI-A05	Ø14	75	38
MFI-A06	Ø14	85	40
MFI-A07	Ø20	105	55
MFI-A08	Ø30	115	95

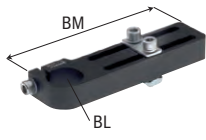

Staffa robusta / Heavy duty mounting bracket / Schwerlast-Winkelklemmstück / Bride robuste / Unión de montaje robusta / Abraçadeira resistente / Uchwyt montażowy wzmocniony / Ağır şartlar için montaj braketi / 重型固定支架 / 헤비듀티어取付 브라켓 / 고강도 장착 브라켓

	BL [mm]	BM [mm]	m [g]
MFI-A207	Ø10	70	30
MFI-A209	Ø14	85	60
MFI-A205	Ø20	105	85
MFI-A206	Ø30	115	175

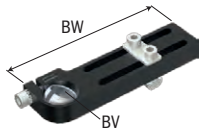

Staffa robusta con giunto sferico / Heavy-duty mounting bracket with ball joint / Schwerlast-Winkelklemmstück mit Kugelgelenk / Bride robuste avec raccord sphérique / Unión de montaje robusta con junta esférica / Suporte robusto com junta esférica / Wzmocnione złącze montażowe z przegubem kulowym / Ağır şartlar için bilyeli mafsallı montaj braketi / 带有球关节的重型安装支架 / 볼ジョ인트付き헤비듀티어一仕様 브라켓 / 볼 조인트형 고하중용 고정 브라켓

	BV [mm]	BW [mm]	m [g]	
MFI-A348	NEW	Ø10	85	45
MFI-A349	NEW	Ø14	105	86
MFI-A350	NEW	Ø20	115	160

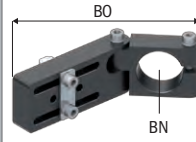

Staffa robusta / Heavy duty mounting bracket / Schwerlast-Winkelklemmstück / Bride robuste / Unión de montaje robusta / Abraçadeira resistente / Uchwyt montażowy wzmocniony / Kanallı açılı braket / 重型固定支架 / 헤비듀티어取付 브라켓 / 고강도 장착 브라켓

	BN [mm]	BO [mm]	m [g]
MFI-A250	Ø10	64,5	30
MFI-A251	Ø14	85	50
MFI-A252	Ø20	107	90
MFI-A253	Ø30	135,5	185



Staffa / Mounting bracket / Winkelklemmstück / Bride de fixation / Unión de montaje / Suporte de fixação / Uchwyt montażowy / Montaj braketi / 固定支架 / 取付ブラケット / 장착 브라켓

	EMF	BP [mm]	m [g]	
MFI-A09	NEW	2525, 5025	Ø14	50
MFI-A10	NEW	2525, 5025	Ø20	70
MFI-A36	NEW	4040, 8040	Ø20	95
MFI-A34	NEW	2525, 5025	Ø30	90
MFI-A35	NEW	4040, 8040	Ø30	150

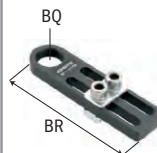

Staffa / Mounting bracket / Winkelklemmstück / Bride de fixation / Unión de montaje / Suporte de fixação / Uchwyt montażowy / Montaj braketi / 固定支架 / 取付ブラケット / 장착 브라켓

	BQ [mm]	BR [mm]	m [g]
MFI-A104	G1/8"	75	25
MFI-A105	G1/8"	105	42
MFI-A106	M10x1	75	30
MFI-A107	M10x1	105	40
MFI-A266	M12x1	75	35
MFI-A267	M12x1	105	50
MFI-A108	M14x1	75	20
MFI-A109	M14x1	105	40
MFI-A210	M14x1.5	75	20
MFI-A211	M14x1.5	105	40
MFI-A110	M16x1	75	20
MFI-A111	M16x1	105	40
MFI-A112	M20x1.5	75	30
MFI-A113	M20x1.5	105	35
MFI-A268	M25x1.5	85	55
MFI-A269	M25x1.5	115	70
MFI-A114	-	75	25
MFI-A115	-	105	40



Moduli di fissaggio  
 Modular clamping system  
 Klemmstücke  
 Modules de fixation  
 Módulos de fijación  
 Módulos de fixação  
 System mocowania modułowego  
 Modüler bağlantı sistemi  
 模块化紧固系统  
 모듈러·클램핑시스템  
 모듈형 클램프 시스템

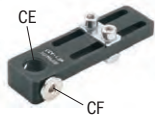

Staffa lunga per ventosa / Long mounting bracket for vacuum cup / Langes Winkelstück für Saugnapf / Bride longue pour ventouse / Soporte largo para ventosa / Suporte longo para ventosa / Długi wspornik montażowy do przysawek / Vantuz montaj uzun braketi / 真空吸盘长形固定支架 / 真空カップ固定用・取付ブラケット(ロング) / 진공컵용 긴 장착 브라켓

	CE [mm]	CF [mm]	m [g]
<b>MFI-A51</b>	M5	M5	20
<b>MFI-A52</b>	G1/8"	G1/8"	60
<b>MFI-A53</b>	G1/4"	G1/8"	60

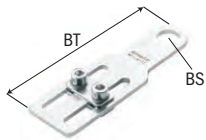

Staffa / Mounting bracket / Winkelklemmstück / Bride de fixation / Unión de montaje / Suporte de fixação / Uchwyt montażowy / Montaj braketi / 固定支架 / センサーボックス固定用ブラケット / 장착 브라켓

	BS [mm]	BT [mm]	m [g]
<b>MFI-A116</b>	Ø10.5	100	60
<b>MFI-A117</b>	Ø12.5	100	60
<b>MFI-A118</b>	Ø14.5	100	60
<b>MFI-A119</b>	Ø16.5	100	65
<b>MFI-A120</b>	Ø20.5	100	60
<b>MFI-A181</b>	Ø22.5	100	105
<b>MFI-A182</b>	Ø25.5	100	100
<b>MFI-A121</b>	Ø10.5	65	45
<b>MFI-A122</b>	Ø12.5	65	45
<b>MFI-A123</b>	Ø14.5	65	45
<b>MFI-A124</b>	Ø16.5	65	45
<b>MFI-A125</b>	Ø20.5	65	40
<b>MFI-A183</b>	Ø22.5	70	75
<b>MFI-A184</b>	Ø25.5	70	70



Staffa per attacco diretto ventosa / Direct connector for vacuum cup / Saugeranschluss / Bride de fixation directe pour ventouse / Soporte para la unión directa de la ventosa / Suporte de fixação directa para ventosa / Uchwyt do bezpośredniego mocowania przysawek / Vantuz doğrudan montaj braketi / 真空吸盘连接器 / 真空カップ固定用・取付コネクタ / 진공컵용 다이렉트 커넥터

	CA [mm]	CB [mm]	m [g]
<b>MFI-A46</b>	G1/8"	G1/8"	42
<b>MFI-A47</b>	G1/8"	G1/4"	40



Staffa per ventosa / Mounting bracket for vacuum cup / Winkelstück für Saugnapf / Bride pour ventouse / Soporte para la unión directa de la ventosa / Suporte de fixação directa para ventosa / Uchwyt montażowy do przysawek / Vantuz montaj braketi / 真空吸盘固定支架 / 真空カップ固定用・取付ブラケット / 진공컵용 장착 브라켓

	CC [mm]	CD [mm]	m [g]
<b>MFI-A48</b>	M5	M5	15
<b>MFI-A49</b>	G1/8"	G1/8"	45
<b>MFI-A50</b>	G1/8"	G1/4"	45



Staffa ad angolo regolabile per ventosa / Adjustable angle connector for vacuum cup / Winkelstück 360° drehbar für Saugnapf / Bride angulaire pour ventouse / Soporte de ángulo regulable para ventosa / Suporte angular para ventosa / Regulowany wspornik kątowy do przysawek / Vantuz için açısı ayarlanabilir montaj braketi / 真空吸盘可调角度连接器 / 真空カップ固定用・取付コネクタ(角度調整可能) / 진공컵용 각도 조절이 가능한 커넥터

	CG [mm]	CH [mm]	m [g]
<b>MFI-A54</b>	M5	M5	15
<b>MFI-A55</b>	G1/8"	G1/8"	45
<b>MFI-A56</b>	G1/4"	G1/8"	42



Gambo per ventosa / Leg for vacuum cup / Greifarm für Saugnapf / Bras porte ventouse / Mango para ventosa / Haste para ventosa / Ramię do przysawki / Vantuz uzatma aparati / 真空吸盘支架 / 真空カップ固定用シャフト / 진공컵 다리

	CNxCM [mm]	CI [mm]	CL [mm]	m [g]
<b>MFI-A170</b>	Ø10x30	M5	M5	10
<b>MFI-A171</b>	Ø10x60	M5	M5	13
<b>MFI-A172</b>	Ø10x90	M5	M5	17
<b>MFI-A71</b>	Ø14x40	G1/8"	G1/8"	17
<b>MFI-A72</b>	Ø14x80	G1/8"	G1/8"	25
<b>MFI-A73</b>	Ø14x120	G1/8"	G1/8"	32
<b>MFI-A74</b>	Ø20x50	G1/4"	G1/8"	40
<b>MFI-A75</b>	Ø20x100	G1/4"	G1/8"	60
<b>MFI-A76</b>	Ø20x150	G1/4"	G1/8"	75

Moduli di fissaggio  
 Modular clamping system  
 Klemmstücke  
 Modules de fixation  
 Módulos de fijación  
 Módulos de fixação  
 System mocowania modułowego  
 Modüler bağlantı sistemi  
 模块化紧固系统  
 モジューラー・クランピングシステム  
 모듈형 클램프 시스템



Gambo con cravatta / Clamp leg / Winkelarm mit Klemmstück / Bras avec élément de serrage / Abrazadera con mango / Haste com elemento de aperto / Ramię zaciskowe / Uzatma aparatı / 夹腿 / 締め付け固定用シャフト / 클램프 다리

	CQ x CP [mm]	CO [mm]	m [g]
MFI-A93	Ø10x15	Ø10	8
MFI-A158	Ø10x30	Ø10	10
MFI-A159	Ø10x60	Ø10	15
MFI-A160	Ø10x90	Ø10	20
MFI-A157	Ø14x20	Ø14	15
MFI-A161	Ø14x40	Ø14	20
MFI-A162	Ø14x80	Ø14	30
MFI-A163	Ø14x120	Ø14	40
MFI-A94	Ø20x25	Ø20	35
MFI-A77	Ø20x50	Ø20	45
MFI-A78	Ø20x100	Ø20	70
MFI-A79	Ø20x150	Ø20	105
MFI-A95	Ø20x25	Ø30	60
MFI-A203	Ø30x40	Ø30	130
MFI-A164	Ø30x80	Ø30	170
MFI-A165	Ø30x140	Ø30	230
MFI-A166	Ø30x200	Ø30	300



Blocco distributore laterale / Side manifold block / Verteilerblock / Bloc distributeur latéral / Bloque distribuidor lateral / Bloco de distribuição lateral / Rozgałęźnik boczny / Yan manifold bloğu / 側边多方位组 / 配管分岐用マニホールド(側面取出) / 측면 매니폴드 블럭

	CR	m [g]
MFI-A68	G1/8" (n°5)	30
MFI-A69	G1/8" (n°9)	50
MFI-A70	G1/8" (n°10)	48



Blocco distributore / Manifold block / Luftverteiler / Bloc distributeur / Bloque distribuidor / Bloco distribuidor / Rozgałęźnik / 4'lü manifold bloğu / 多方位组 / 配管分岐用マニホールド / 매니폴드 블럭

	CS	m [g]
MFI-A66	G1/8" (x5)	50
MFI-A67	G1/4" (x5)	80



Supporto orientabile / Swivelling support / Schwenkbare Halterung / Support orientable / Soporte orientable / Suporte orientável / Wspornik obrotowy / Ayarlanabilir destek / 旋转支撑 / アクチュエータ固定用スイベル / 선회 지원

	CV [mm]	CT	m [g]
MFI-A212	Ø20	G1/8"	30
MFI-A213	Ø20	M16x1	40



Blocco di connessione a croce / Cross connection block / Kreuz-Verbindungsblock / Bloc de connexion en croix / Bloque de conexión en cruz / Bloco de ligação em cruz / Krzyżowe złącze montażowe / Çapraz bağlama bloğu / 交叉连接块 / アクチュエータ固定用ブロック / 교차 연결 블럭

	DA [mm]	DB [mm]	m [g]
MFI-A214	Ø20	Ø10	40
MFI-A215	Ø20	Ø14	45
MFI-A216	Ø20	Ø20	70

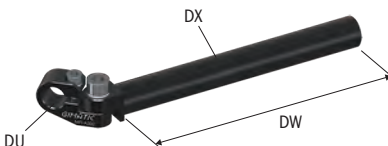

Gambo con cravatta robusto / Heavy duty clamp leg / Robuster Winkelarm mit Klemmstück / Bras avec élément de serrage robuste / Abrazadera con mango robusta / Haste de fixação ajustável / Ramię zaciskowe o dużej wytrzymałości / Ağır şartlar için ayarlanabilir uzatma aparatı / 重型应用 夹腿 / 高耐久性クランプ脚 / 대형 클램프 암

	DX x DW [mm]	DU [mm]	m [g]
MFI-A332	Ø14x120	Ø10	50

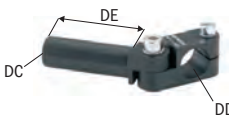

Gomito con cravatta / Elbow arm / Gelenkarm mit Klemmstück / Bras de préhension ajustble / Codo con abrazadera / Braço de fixação ajustável / Ramię kątowe / Açısı ayarlanabilir uzatma aparatı / 弯臂 / アクチュエータ固定用エルボ / 엘보우 암

	DC x DE [mm]	DD [mm]	m [g]
MFI-A59	Ø10x60	Ø10	20
MFI-A60	Ø14x40	Ø14	32
MFI-A61	Ø14x80	Ø14	42
MFI-A62	Ø14x120	Ø14	50
MFI-A63	Ø20x50	Ø20	70
MFI-A64	Ø20x100	Ø20	90
MFI-A65	Ø20x150	Ø20	120
MFI-A167	Ø30x80	Ø30	235
MFI-A168	Ø30x140	Ø30	300
MFI-A169	Ø30x200	Ø30	360

**Moduli di fissaggio**  
**Modular clamping system**  
**Klemmstücke**  
**Modules de fixation**  
**Módulos de fijación**  
**Módulos de fixação**  
**System mocowania modułowego**  
**Modüler bağlantı sistemi**  
**模块化紧固系统**  
**モジュラー・クランピングシステム**  
**모듈형 클램프 시스템**



Snodo robusto con cravatta / Heavy duty elbow arm / Schwerlast-Gelenkarm mit Klemmstück / Coude robuste avec cravate / Codo con abrazadera robusto / Haste com ajuste angular resistente / Ramię kątowe wzmocnione / Ağır şartlar için açısı ayarlanabilir uzatma aparatı / 重型弯臂 / アクチュエータ固定用・ヘビーデューティ・エルボ / 고강도 엘보우 암

	DF x DE [mm]	DG [mm]	m [g]
<b>MFI-A195</b>	Ø20x50	Ø20	95
<b>MFI-A199</b>	Ø20x100	Ø20	115
<b>MFI-A200</b>	Ø20x150	Ø20	130
<b>MFI-A196</b>	Ø30x80	Ø30	330
<b>MFI-A197</b>	Ø30x140	Ø30	380
<b>MFI-A198</b>	Ø30x200	Ø30	435

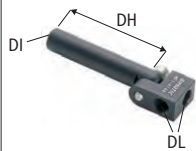

Gomito per ventosa / Elbow arm for vacuum cup / Gelenkarm für Saugnapf / Bras porte ventouse ajustable / Codo para ventosa / Braço porta ventosa ajustável / Ramię kątowe do przyssawki / Açısı ayarlanabilir vantuz uzatma aparatı / 真空吸盘弯臂 / 真空カップ固定用エルボ / 진공컵용 엘보우 암

	DI x DH [mm]	DL [mm]	m [g]
<b>MFI-A142</b>	Ø10x45	M5	18
<b>MFI-A143</b>	Ø10x90	M5	27
<b>MFI-A144</b>	Ø14x60	G1/8"	33
<b>MFI-A145</b>	Ø14x120	G1/8"	50
<b>MFI-A146</b>	Ø20x78	G1/8"	60
<b>MFI-A147</b>	Ø20x153	G1/8"	100
<b>MFI-A148</b>	Ø20x75	G1/4"	75
<b>MFI-A149</b>	Ø20x150	G1/4"	115



Gomito a cravatta per ventosa / Elbow arm for vacuum cup clamping / Winkel-Klemmverbindung für Saugnapf / Coude à support pour ventouse / Codo con abrazadera para ventosa / Ramię kątowe zaciskowe do przyssawki / Braço para ventosa com ângulo / Vantuz bağlamak için uzatma aparatı / 真空吸盘弯臂 / 真空カップ取付用エルボ / 진공컵 클램프용 엘보우 암

	DN x DM [mm]	DO [mm]	m [g]
<b>MFI-A256</b>	Ø10x30	M5	14
<b>MFI-A257</b>	Ø10x60	M5	17
<b>MFI-A258</b>	Ø10x90	M5	20
<b>MFI-A259</b>	Ø14x40	G1/8"	32
<b>MFI-A260</b>	Ø14x80	G1/8"	40
<b>MFI-A261</b>	Ø14x120	G1/8"	48
<b>MFI-A290</b>	Ø20x50	G1/8"	63
<b>MFI-A291</b>	Ø20x100	G1/8"	78
<b>MFI-A292</b>	Ø20x150	G1/8"	93
<b>MFI-A262</b>	Ø20x50	G1/4"	58
<b>MFI-A263</b>	Ø20x100	G1/4"	73
<b>MFI-A264</b>	Ø20x150	G1/4"	88



Prolunga con canale per l'aria / Extension tube with air lead / Verlängerungsröhre mit Luftkanal / Prolongateur avec canal d'air / Prolongación con conducto para el aire / Extensão com canal de ar / Rura przedłużająca z kanałem powietrza / Uzatma borusu / 空气导管延长管 / 配管延長用パイプ / 공기 리드가 장착된 익스텐션 튜브

	DQ x DP [mm]	DR [mm]	m [g]
<b>MFI-A154</b>	Ø10x45	M5	10
<b>MFI-A155</b>	Ø10x90	M5	15
<b>MFI-A150</b>	Ø14x45	G1/8"	15
<b>MFI-A151</b>	Ø14x90	G1/8"	25
<b>MFI-A152</b>	Ø20x45	G1/4"	30
<b>MFI-A153</b>	Ø20x90	G1/4"	55



Staffa per il montaggio di tre unità / Mounting bracket for three units / Befestigungsplatte zur Befestigung von drei Einheiten / Bride pour le montage de trois unités / Elemento de unión para el montaje de tres unidades OFX2010 / Suporte para montagem de três unidades / Uchwyt montażowy dla trzech urządzeń / 3'ü montaj braketi / 可安装3个模块的安装支架 / OFX2010固定用・3点取付ブラケット / 3개 장치에 대한 장착 브라켓

	DS (mm)	m [g]
<b>MFI-A194</b>	Ø20	200



Staffa per il montaggio della pinza OFP20 su profilo / OF20 gripper mounting bracket, to use with profile / Befestigungsplatte zur Befestigung des Greifers OFP20 an Profil / Bride pour le montage de la pince OFP20 sur profilé / Soporte para el montaje de la pinza OFP20 sobre el perfil / Suporte para montagem de pinça OFP20 no perfil / Uchwyt do montażu chwytaka OFP20 do profilu / OFP20 tutucu için profil montaj braketi / OFP20气夹安装支架, 与型材搭配使用 / OFP20固定用・取付ブラケット / OF20 그리퍼 장착용 브라켓 (프로파일에 사용)

	m [g]
<b>MFI-A176</b>	95

Moduli di fissaggio  
 Modular clamping system  
 Klemmstücke  
 Modules de fixation  
 Módulos de fijación  
 Módulos de fixação  
 System mocowania modułowego  
 Modüler bağlantı sistemi  
 模块化紧固系统  
 모듈러·클램핑시스템  
 모듈형 클램프 시스템

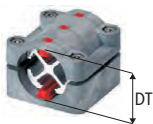

Kit di bloccaggio per estruso / Single block assembly / Klemmstücke für Einzel-Pressprofil / Kit de blocage pour profilé / Kit de bloqueo para el tubo extruido / Kit de bloqueio para perfil / Element blokujący dla pojedynczego profilu ekstrudowanego / Tek montaj bloğu / 单个锁紧模块 / 프로파일용·블록 (交差·外周固定) / 단일 블럭 어셈블리

	DT [mm]	m [g]
<b>MFI-A188</b>	Ø20	48
<b>MFI-A189</b>	Ø30	77
<b>MFI-A190</b>	Ø50	510

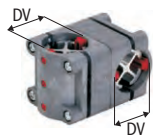

Kit di bloccaggio per doppio estruso / Double block assembly / Klemmstücke für Doppel-Pressprofil / Kit de blocage pour double profilés / Kit de bloqueo para doble tubo extruido / Kit de bloqueio para perfil duplo / Element blokujący dla podwójnego profilu ekstrudowanego / Çift montaj bloğu / 双模块安装件 / 프로파일용·블록 (外周·外周固定) / 이중 블럭 어셈블리

	DV [mm]	m [g]
<b>MFI-A191</b>	Ø20	77
<b>MFI-A192</b>	Ø30	122
<b>MFI-A193</b>	Ø50	930



Linguette di centraggio tonde / Rounded centering feather keys / Zentrierfederkeile für runde Befestigungsteile / Languettes de centrage rondes / Lengüetas de centrado redondeadas / Lingueta de centragem redonda / Kliny centrujące zaokrąglone / Yuvarlak merkezli kama / 定心卡轮 / 프로파일용·위치결정용·키 / 원형 센터링 페더키

		m [g]
<b>MFI-A185</b>	EMB-2017	10 (1)
<b>MFI-A186</b>	EMB-3026	20 (1)
<b>MFI-A187</b>	EMB-5045	40 (1)

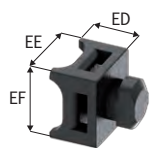

Staffa per fissaggio cavi / Cable mounting bracket / Befestigungsbügel für Kabeln / Bride de fixation câbles / Soporte para fijación de cables / Suporte de fixação de cabos / Uchwyt kablowy / Hortum montaj braketi / 软管固定支架 / 밴드용·브라켓 / 호스 장착 브라켓

	ED [mm]	EE [mm]	EF [mm]	m [g]
<b>MFI-A239</b>	10.5	16	16	20 (1)

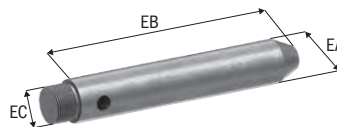

Spina di centraggio filettata / Threaded centering pin / Zentrierstift mit Gewinde / Douille de centrage fileté / Pin de centrado roscado / Pino de centragem / Trzpień centrujący gwintowany / Dişli merkezleme pini / 螺旋定位销 / 心立てねじピン / 나사산이 있는 센터링 핀

	EA [mm]	EC	EB [mm]	m [g]
<b>MFI-A235</b>	Ø10	M8x1	60	7
<b>MFI-A236</b>	Ø14	M12x1	80	20
<b>MFI-A237</b>	Ø20	M17x1	100	45
<b>MFI-A238</b>	Ø30	M27x1	100	45



Porta sensore Ø18 / Sensor holder Ø18 / Sensorhalter Ø18 / Porte-captteur Ø18 / Soporte para sensor Ø18 / Suporte do sensor Ø18 / Uchwyt czujnika Ø18 / Ø18 Sensör tutacağı / 传感器支架Ø18 / 센서홀더 (Ø18mm) / 센서홀더(Ø18)

	m [g]
<b>MFI-A310</b>	47

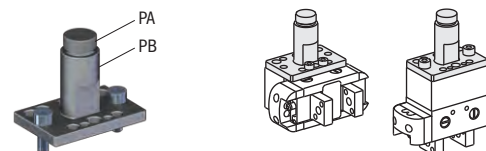

Staffa per fissaggio pinza / Gripper mounting bracket / Befestigungsbügel für Greifer / Bride pour fixation pince / Soporte para fijación de pinza / Suporte de fixação da pinça / Uchwyt do montażu chwytaka / Tutucu montaj braketi / 夹具安装支架 / 그리퍼·브라켓 / 取付用·브라켓 / 그리퍼 장착 브라켓

		PA	PB [mm]	m [g]
<b>MFI-A314</b>	AA, SGP-40S	M12x1	Ø14	25
<b>MFI-A315</b>	SGP-32S	M8x1	Ø10	11
<b>MFI-A316</b>	SGP-25S	M8x1	Ø10	9
<b>MFI-A317</b>	SGP-20S	M8x1	Ø10	7
<b>MFI-A318</b>	PQ1608	M8x1	Ø10	11
<b>MFI-A319</b>	PQ2012	M12x1	Ø14	18
<b>MFI-A320</b>	PQ2516	M12x1	Ø14	20
<b>MFI-A321</b>	GS-10, GW-10	M8x1	Ø10	8
<b>MFI-A322</b>	GS-16, GW-16	M12x1	Ø14	18
<b>MFI-A323</b>	GS-20, GW-20	M12x1	Ø14	29
<b>MFI-A324</b>	GS-25, GW-25	M17x1	Ø20	57
<b>MFI-A325</b>	SZ12	M12x1	Ø14	33
<b>MFI-A326</b>	SZ16	M12x1	Ø14	41
<b>MFI-A327</b>	SZ25	M17x1	Ø20	140

(1) Confezione da 10 pezzi / 10 pieces package / 10 Stück Packing / Vendu par 10 pièces / Paquete de 10 piezas / Embalagem de 10 peças / 10 sztuk w opakowaniu / Her paket 10 Adettir / 10个一包 / 一袋10个入 / 10피스 패키지

**Moduli di fissaggio**  
**Modular clamping system**  
**Klemmstücke**  
**Modules de fixation**  
**Módulos de fijación**  
**Módulos de fixação**  
**System mocowania modułowego**  
**Modüler bağlantı sistemi**  
**模块化紧固系统**  
**モジュラー・クランピングシステム**  
**모듈형 클램프 시스템**



Basetta per fissaggio pinza / Gripper mounting bracket / Befestigungshalter für Greifer / Support pour fixation pince / Soporte para la fijación de la pinza / Suporte para fixação de pinça / Uchwyt do montażu chwybaka / Ø20 tutucu montaj braketi (vidali kit) / 夹具安装支架 / 그리퍼-취付용 브라켓 / 그리퍼 장착 브라켓

	EH x EG [mm]	m [g]
<b>MFP-A04</b>	Ø10x15 GS-10, GW-10, SGP-25S	5
<b>MFP-A01</b>	Ø20x48 AA, GS-16, GW-16, SGP-32S	26

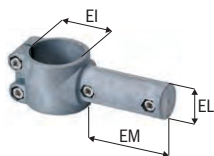

Staffa in plastica / Polymer mounting bracket / Klemmstück aus Kunststoff / Bras de préhension / Abrazadera en plástico / Suporte / Uchwyt montażowy polimerowy / Montaj braketi (2 yarım parça + vidalar) / 塑料支架 / 플라스틱製·취付 브라켓 / 폴리머 장착 브라켓

	EI [mm]	EL x EM [mm]	m [g]
<b>MFP-A08</b>	Ø30	Ø20x48	48
<b>MFP-A05</b>	Ø36	Ø20x48	54
<b>MFP-A06</b>	Ø45	Ø20x48	65
<b>MFP-A07</b>	Ø56	Ø20x48	82



Staffa Ø20-10 in plastica / Polymer mounting bracket Ø20-10 / Klemmstück Ø20-10 aus Kunststoff / Bras de préhension Ø20-10 en plastique / Abrazadera Ø20-10 en plástico / Suporte Ø 20-10 / Uchwyt montażowy polimerowy Ø20-10 / Montaj braketi Ø20-10 (2 yarım parça + vidalar) / 直径为20-10的塑料支架 / 플라스틱製·취付 브라켓 (Ø 20-10) / 폴리머 장착 브라켓 Ø20-10

	EP [mm]	EO x EN [mm]	m [g]
<b>MFP-A03</b>	Ø10	Ø20x48	35

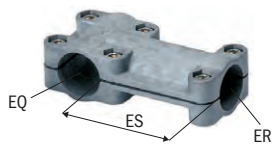

Giunto angolare in plastica / Polymer T connector / Winkelklemmstück aus Kunststoff / Connexion angulaire en plastique / Junta angular en plástico / Conexão angular em plástico / Łącznik T z tworzywa sztucznego / Polimer T birleştirici (2 yarım parça + vidalar) / T型塑料连接器 / 플라스틱製·T型コネクター / 폴리머 T 커넥터

	EQ [mm]	ER x ES [mm]	m [g]
<b>MFP-A02</b>	Ø20	Ø20x48	53
<b>MFP-A09</b>	Ø30	Ø30x48	82

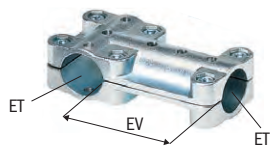

Giunto angolare in acciaio / Steel T connector / Winkelklemmstück aus Stahl / Connexion angulaire en acier / Junta angular en acero / Conexão angular em aço / Stalowy łącznik T / Çelik T bileştirici (2 yarım parça + vidalar) / 钢制T型连接器 / 스틸製·T型코ネク터 / 스틸 T 커넥터

	ET [mm]	ET x EV [mm]	m [g]
<b>MFM-A02</b>	Ø20	Ø20x48	200
<b>MFM-A09</b>	Ø30	Ø30x48	328
<b>MFM-A85</b>	Ø50	Ø50x70	660



Staffa in acciaio / Steel mounting bracket / Klemmstück aus Stahl / Bride en acier / Abrazadera de acero / Suporte em aço / Uchwyt stalowy / Çelik montaj braketi / 钢制固定支架 / 스틸製·취付 브라켓 / 스틸 장착 브라켓

	FA [mm]	FB [mm]	m [g]
<b>MFM-A30</b>	15	Ø30	69
<b>MFM-A36</b>	15	Ø36	75
<b>MFM-A45</b>	15	Ø45	80
<b>MFM-A56</b>	15	Ø56	102

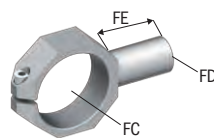

Staffa in alluminio / Aluminium mounting bracket / Klemmstück aus Aluminium / Bride en aluminium / Abrazadera en aluminio / Suporte em alumínio / Uchwyt aluminiowy / Alüminyum montaj braketi / 铝制固定支架 / 알루미늄製·취付 브라켓 / 알루미늄 장착 브라켓

	FC [mm]	FD x FE [mm]	m [g]
<b>MFM-A110</b>	Ø36	Ø14x25	30
<b>MFM-A111</b>	Ø45	Ø20x35	65
<b>MFM-A112</b>	Ø56	Ø20x40	110
<b>MFM-A11</b>	Ø75	Ø30x48	308

Moduli di fissaggio  
 Modular clamping system  
 Klemmstücke  
 Modules de fixation  
 Módulos de fijación  
 Módulos de fixação  
 System mocowania modułowego  
 Modüler bağlantı sistemi  
 模块化紧固系统  
 モジュラー・クランピングシステム  
 모듈형 클램프 시스템

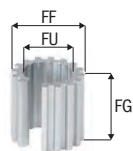

Riduzione / Adapter / Reduzierstück / Réduction / Reducción / Adaptador / Adapter / Adaptör / 适配器 / 丸型レデューサー / 어댑터

	FU [mm]	FF [mm]	FG [mm]	m [g]
<b>MFM-A120</b>	Ø10	Ø14	13	3
<b>MFM-A114</b>	Ø12	Ø14	14	2
<b>MFM-A55-38</b>	Ø14	Ø20	38	16
<b>MFM-A55-48</b>	Ø14	Ø20	48	19
<b>MFM-A106</b>	Ø16	Ø20	12	5
<b>MFM-A115</b>	Ø16	Ø20	20	6
<b>MFM-A10-20</b>	Ø20	Ø30	20	13
<b>MFM-A10-30</b>	Ø20	Ø30	30	21
<b>MFM-A10-48</b>	Ø20	Ø30	48	33
<b>MFM-A10-48P</b>	Ø20	Ø30	48	24
<b>MFM-A105</b>	Ø24	Ø30	12	8
<b>MFM-A116</b>	Ø25	Ø30	30	17
<b>MFM-A96</b>	Ø30	Ø50	65	240

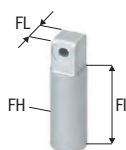

Supporto orientabile / Hinge with stud / Gelenkhalter mit Rohr / Support orientable / Soporte orientable / Suporte orientável / Wspornik obrotowy / Somunlu mafsal / 可调支架 / 액츄에이터固定용스이벨 / 스테르가 있는 힌지

	FL [mm]	FH x FI [mm]	m [g]
<b>MFM-A17</b>	15	Ø20x48	56
<b>MFM-A18</b>	15	Ø30x48	82

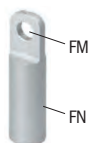

Supporto per sospensioni / Holder for suspensions / Halter für gefederte Aufhängung / Support pour suspensions / Soporte para suspensión / Suporte para suspensão / Uchwyt do zawieszania / Süspansiyon tutacağı / 悬件支架 / サスペンション用ホルダー / 서스펜션용 홀더

	FM [mm]	FN [mm]	m [g]
<b>MFM-A19</b>	Ø10.5	Ø20	52
<b>MFM-A20</b>	Ø12.5	Ø20	52
<b>MFM-A21</b>	Ø14.5	Ø20	52
<b>MFM-A22</b>	Ø16.5	Ø30	84
<b>MFM-A23</b>	Ø20.5	Ø30	86



Bloccetto di fissaggio per PB / PB mounyng connector / Befestigungsteil für PB / Cale de fixation pour PB / Bloque de fijación para PB / Calço de fixação para PB / Łącznik montażowy PB / PB tutucu için montaj konektörü / PB固定连接器 / 스프링클러용 PB용·取付コネクタ / PB 장착 커넥터

	m [g]
<b>MFM-A57</b>	25



Interfaccia per pinze / Interface for gripper / Schnittstelle für Greifer / Interface pour pincas / Interfaz para pinzas / Interface para pinças / Złącze dla chwytaków / Tutucular için vidalı arayüz / 气夹接口 / グリッパ用インターフェース / 그리퍼용 인터페이스

		FP [mm]	m [g]
<b>i30K</b>	GS-10, GW-10	G1/8"	9
<b>i31K</b>	GS-16, GW-16	G1/8"	14
<b>i32K</b>	GS-20, GW-20	G1/8"	14
<b>i33K</b>	GS-25, GW-25	M15x1	43
<b>i34K</b>	AA-22, AA-23, AA-26, AA-35	M10x1	65
<b>i35K</b>	AA-25	M10x1	65
<b>i36K</b>	PE-16	M16x1	190
<b>i37K</b>	AA-22, AA-23, AA-26, GS-16, GW-16, SGP-32S	M10x1	85

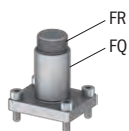

Interfaccia per taglierino GNS / GNS nipper mounting bracket / Schnittstelle für Schneidzange GNS / Interface pour pince coupante GNS / Interfaz para tijera GNS / Interface para pinça GNS / Uchwyt do szczypiec tnących GNS / GNS kesici makas montaj braketi / GNS剪鉗固定支架 / 니퍼-GNS용·取付브라켓 / GNS 니퍼 장착 브라켓

	FR [mm]	FQ [mm]	m [g]
<b>MFM-A107</b>	M17x1	Ø20	30
<b>MFM-A108</b>	M17x1	Ø20	35
<b>MFM-A109</b>	M27x1	Ø30	100



Interfaccia per cilindro guidato / Interfaces for guided cylinder / Schnittstellen für geführten Zylinder / Interface pour vérin guidé / Interface para el cilindro guiado / Interface para cilindro guiado / Przyłącza dla cylindra prowadzącego / Silindirler için uzatma borusu / 驱动气缸接口 / 가이드付シリン더用インターフェース / 가이드 실린더용 인터페이스

	m [g]
<b>MFM-A117</b>	70

**Moduli di fissaggio**  
**Modular clamping system**  
**Klemmstücke**  
**Modules de fixation**  
**Módulos de fijación**  
**Módulos de fixação**  
**System mocowania modułowego**  
**Modüler bağlantı sistemi**  
**模块化紧固系统**  
**モジュラー・クランピングシステム**  
**모듈형 클램프 시스템**



Interfaccia per cilindro guidato / Interfaces for guided cylinder / Schnittstellen für geführten Zylinder / Interface pour vérin guidé / Interface para el cilindro guiado / Interface para cilindro guiado / Przyłącza dla cylindra prowadzącego / Silindirlar için kılavuzlu arayüz / 驱动气缸接口 / ガイド付シリンダー用インターフェース / 가이드 실린더용 인터페이스

		m
		[g]
<b>MFM-A118</b>	OFB40-...50	80
<b>MFM-A119</b>	OFB40-...30	60

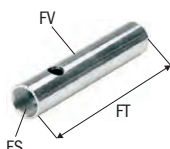

Tubo di prolunga / Extension tube / Verlängerungsrohr / Rallonge / Tubo de prolongación / Tubo de extensão / Rura przedłużająca / Uzatma borusu / 延长管 / エクステンションチューブ / 익스텐션 튜브

	FS	FV x FT	m
	[mm]	[mm]	[g]
<b>OF10L60</b>	M8x1	Ø10x60	7
<b>OF14L80</b>	M12x1	Ø14x80	10
<b>OF20L100</b>	M17x1	Ø20x100	30
<b>OF30L120</b>	M27x1	Ø30x120	65

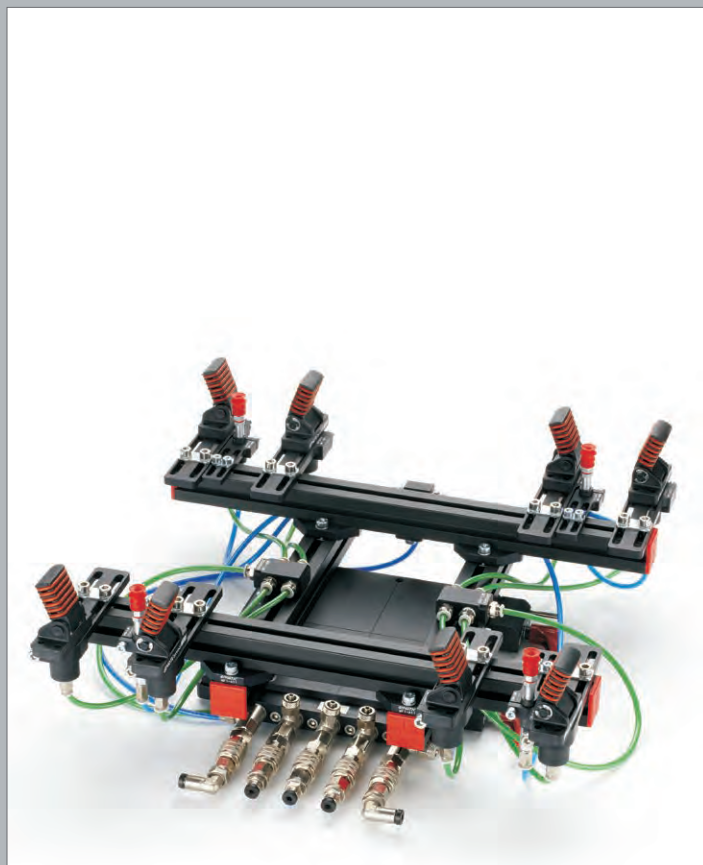

**Connessione al robot**  
**Robot connection**  
**Anschluss an den roboter**  
**Connexion au robot**  
**La conexión al robot**  
**Conexão ao robô**  
**Przyłącze robota**  
**Robot bağlantısı**  
**机械手连接**  
**ロボットへの接続機器**  
**로봇 연결**



Ribaltatori / Tilt units / Kippeinheiten / Culbuteurs / Volteadores / Virador / Elementy obrotowe / Çevirme ünitesi / 倾斜装置 / 取出ヘッド(90度傾倒) / 틸트 유닛

RBT	m	[g]
RBT40	1050	
RBT50	1635	
RBT63	2390	



Ribaltatore per piccoli EOAT / Tilt unit for small EOATs / Kippeinheit für kleine EOAT / Basculeur pour petits EOAT / Volteador para pequeñas garras de manipulación / Basculante para pequenas EOAT / Element obrotowy dla małych EOAT / Küçük robot elleri için çevirme ünitesi / 用于小型治具的倾斜装置 / 小型チャック用・取出ヘッド(90度傾倒) / 소형 EOAT용 틸트 유닛

OFN	m	[g]
OFN30-90	210	



Cambia utensile elettrico / Electric quick changer / Elektrischer Werkzeugwechsler / Changeur d'outil électrique / Cambiador de herramienta eléctrica / Trocador eléctrico rápido / Elektryczny system szybkiego zmieniania / Elektrikli çabuk deęiřtirici / 电动快速更换器 / 電動ツールチェンジャー / 전기 킷 체인저

EQC	m	[g]
EQC75-A <b>NEW</b>	1000	
EQC75-B <b>NEW</b>	160	
EQC75-K1 <b>NEW</b>	70	
EQC75-K2 <b>NEW</b>	30	

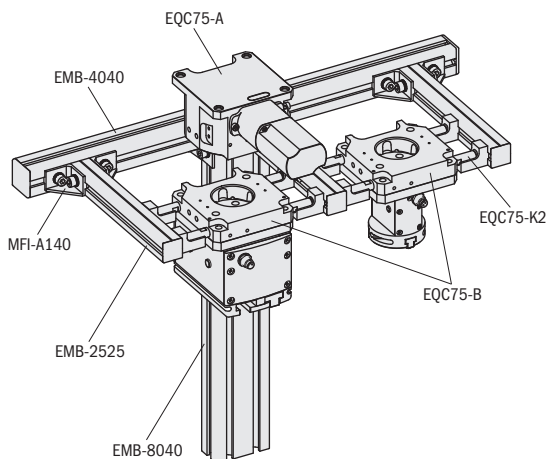

Cambia utensile / Quick changer / Werkzeugwechsler / Changeur d'outil / Cambio rápido de la herramienta / Mudança rápida / System szybkiego zmieniania / Çabuk deęiřtirici / 快速转换模块 / ツールチェンジャー / 킷 체인저

QC	m	[g]
QC50-A	103	
QC50-B	65	
QC90-A	318	
QC90-B	227	
QCX90-A	595	
QCY90-A <b>NEW</b>	350	
QC150-A	1123	
QC150-B	827	
QCX150-A	2200	
QC160-A	1200	
QC160-B	900	
QCX160-A	2200	
QC200-A	2640	
QC200-B	1890	
QCX200-A	4900	



Magazzino per EOAT / EOAT Storage / Lagerung EOAT / Dépôt pour main de préhension / Soporte para almacenamiento de la EOAT / Suporte para EOAT / Zasobnik EOAT / Robot eli askı aparatı / 治具存放架 / チャック固定用・治具 / EOAT 스토리지

	m	[g]
QC50-H	190	
QC90-H	420	
QC150-H	950	
QC200-H	1900	



Attuatore pneumatico per cambia utensile QC / Pneumatic actuator for quick changer QC / Pneumatischer Antrieb für Werkzeugwechsler QC / Vérin pneumatique pour changeur d'outil QC / Actuador neumático para el cambio rápido de herramienta QC / Actuador pneumático para mudanęa de acessórios QC / Siłownik pneumatyczny systemu szybkiego zmieniania QC / QC aparatları için pnömatrik deęiřtirici / 快速转换模块的气动执行器 / ツールチェンジャー用エアアクチュエータ / 킷 체인저 QC용 공압 액츄에이터

AQC	m	[g]
AQC90	560	
AQC150	1480	



**Connessione al robot**  
**Robot connection**  
**Anschluss an den roboter**  
**Connexion au robot**  
**La conexión al robot**  
**Conexão ao robô**  
**Przyłącze robota**  
**Robot bağlantısı**  
**机械手连接**  
**ロボットへの接続機器**  
**로봇 연결**



Modulo di connessione elettrica / Electrical connection module /  
 Elektroverbindungsmodul / Module de connexion électrique /  
 Cambio rápido de la herramienta / Mudança rápida / Elektryczny moduł przyłączeniowy  
 / Elektriksel bağlantı modülü / 电气连接模块 / 電気配線用モジュール / 전기 배선 모듈

C-QC		m
		[g]
CAQC		30
CBQC		30
CEQC-A		97
CEQC-AC		55
CEQC-B		97
CEQC-BC		55
MAQC	NEW	30
MBQC	NEW	30



Unità di blocco per cambia utensili QC / Lock unit for the Quick changers /  
 Verriegelungseinheit für QC Werkzeugwechsler QC / Unité de blocage pour changeur  
 d'outil QC / Unidad de bloqueo para cambio rápido QC / Unidade de bloqueio para  
 mudança rápida QC / Element blokujący systemu zmieniania narzędzi QC / QC çabuk  
 değiştirici için kilit ünitesi / 快换的锁紧模块 / ツールチェンジャー用ロックユニット /  
 QC 톨체인저용 잠금 장치

LOQC		m
		[g]
LOQC		20



Scatola di derivazione per sensori / Sensor box / Klemmenkasten / Boîte de dérivation  
 à capteurs / Cajas de derivación para sensores / Caixas de derivação para sensores  
 / Puszka rozgałęźna czujników / Sensör kutusu / 传感器盒 / センサーボックス / 센서  
 상자

SB		m
		[g]
SB2C		120
SB4C		160
SB6B		193
SB6C		190
SB8C		235
SB8F		165
SB12C		325
SB15		150



Staffa di fissaggio / Mounting bracket / Befestigungsbügel / Bride de fixation /  
 Brida de fijación / Suporte de fixação / Uchwyt montażowy / Montaj braketi /  
 安装支架 / 固定ブラケット / 취부 브라켓

SBA04		m
		[g]
SBA04		140

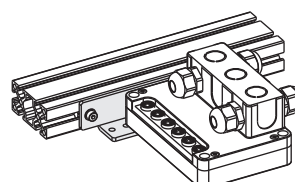

SB6B

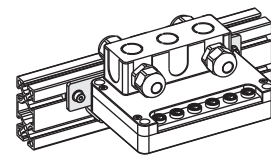

SB6B

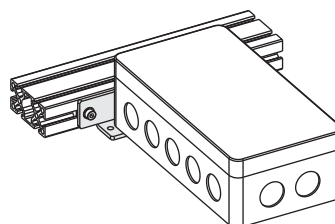

SB12C

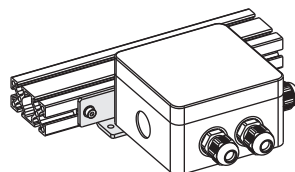

SB6C

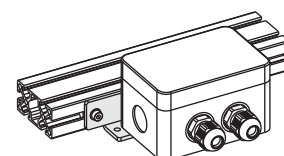

SB4C

Pinze a 1 griffa  
 One finger grippers  
 Ein-finger-greifer  
 Pincas à un doigt de préhension  
 Pinza mono dedo  
 Pinça mono-dedo  
 Chwytyki 1-szczękowe  
 Tek parmaklı tutucular  
 单指气夹  
 ワンフィンガー・グリッパー  
 원 핑거 그리퍼



Pinze per staffaggio angolari / Angular grippers for clamping / Winkelspanngreifer / Pincas pour bridage angulaire / Pinzas de fijación angular mono-dedo / Pinças pneumáticas mono-dedo angulares para fixação / Chwytyki zaciskowe kątowe / Kenetlemeli açılı tutucular / 角度指夹 / ワンフィンガー・グリッパー (35°開閉) / 클램프용 앵글러 그리퍼

OFA	C [Ncm]	s	m [g]
OFA14-35	26	35°	25
OFA20-35	100	35°	65
OFA20-35S	100	35°	86
OFA30-35	430	35°	206
OFA30-35S	430	35°	272
OFA50-35	1900	35°	860
OFA50-35S	1900	35°	1060



Pinze per staffaggio radiali / Radial grippers for clamping / Radialspanngreifer / Pincas pour bridage radiaux / Pinzas de fijación radiales mono-dedo / Pinças pneumáticas mono-dedo radiais para fixação / Chwytyki zaciskowe promieniowe / Kenetlemeli radyal tutucular / 径向气夹 / ワンフィンガー・グリッパー (95°開閉) / 클램프용 방사상 그리퍼

OFR	C [Ncm]	s	m [g]
OFR14-95	19	95°	25
OFR20-95	70	95°	60
OFR20-95S	70	95°	81
OFR30-95	300	95°	193
OFR30-95S	300	95°	257
OFR50-95	1250	95°	790
OFR50-95S	1250	95°	990



Pinze per staffaggio radiali / Radial grippers for clamping / Radialspanngreifer / Pincas pour bridage radiaux / Pinzas de fijación radiales mono-dedo / Pinças pneumáticas mono-dedo radiais para fixação / Chwytyki zaciskowe promieniowe / Kenetlemeli radyal tutucular / 径向单指气夹 / ワンフィンガー・グリッパー (95°開閉) / 클램프용 방사상 그리퍼

OFR-G	C [Ncm]	s	m [g]
OFR14-95G <b>NEW</b>	19	95°	30
OFR20-95G <b>NEW</b>	70	95°	80
OFR20-95SG <b>NEW</b>	70	95°	100
OFR30-95G <b>NEW</b>	300	95°	230
OFR30-95SG <b>NEW</b>	300	95°	300



Pinze per staffaggio radiali / Radial grippers for clamping / Radialspanngreifer / Pincas pour bridage radiaux / Pinzas de fijación radiales mono-dedo / Pinças pneumáticas mono-dedo radiais para fixação / Chwytyki zaciskowe promieniowe / Kenetleme için radyal tutucular / 径向单指气夹 / ワンフィンガー・グリッパー (95°開閉) / 클램프용 방사상 그리퍼

OFS	C [Ncm]	s	m [g]
OFS14-90	19	95°	23
OFS20-90	70	95°	60
OFS20-90S	70	95°	80
OFS30-90	300	95°	185
OFS30-90S	300	95°	245



Guida pinza / Gripper guide / Zentrierstück für Greifer / Guide doigt de préhension / Guia para la pinza / Guia da pinça / Prowadnica chwytaka / Tutucu kılavuz / 气夹导轨 / ワンフィンガー・グリッパー用・ガイド / 그리퍼 가이드

	GB [mm]	m [g]
MFI-A96	Ø20	20
MFI-A97	Ø20	60

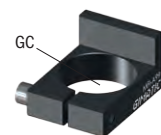

Riscontro per pinze OFS / Stopper for OFS grippers / Stopper für OFS-Greifer / Butée pincas OFS / Tope para la pinza OFS / Batente para pinças OFS / Ogranicznik chwytaków OFS / OFS tutucu için durdurucu / OFS夹具栓 / グリッパー-OFS用・ストッパー / OFS 그리퍼용 스토퍼

	GC [mm]	m [g]
MFI-A271	Ø14	5
MFI-A98	Ø20	14
MFI-A99	Ø30	23



Riscontro per pinze OFR / Stopper for OFR grippers / Stopper für OFR-Greifer / Butée pincas OFR / Tope para la pinza OFR / Batente para pinças OFR / Ogranicznik chwytaków OFR / OFR tutucu için durdurucu / OFR气夹阻块 / グリッパー-OFR用・ストッパー / OFR 그리퍼용 스토퍼

	GD [mm]	m [g]
OFR14G <b>NEW</b>	Ø14	6
OFR20G <b>NEW</b>	Ø20	12
OFR30G <b>NEW</b>	Ø30	30

Pinze a 1 griffa  
 One finger grippers  
 Ein-finger-greifer  
 Pincas à un doigt de préhension  
 Pinza mono dedo  
 Pinça mono-dedo  
 Chwytyki 1-szczękowe  
 Tek parmaklı tutucular  
 单指气夹  
 ワンフィンガー・グリッパー  
 원 핑거 그리퍼



Pinza elastica mono-dito / One finger elastic module / Elastischer Ein-Finger-Greifer / Doigt de préhension élastique / Pinza elástica mono dedo / Pinça elástica mono-dedo / Elastyczny chwytak jednopalcowy / Tek parmak elastik tutucu / 单指模块 / ワンフィンガー・グリッパー (ゴム爪) / 원 핑거 탄성 모듈

OFF	F [N]	s [mm]	m [g]
OFF20	0+145	4.5	40



Pinze per staffaggio perpendicolari / Perpendicular grippers for clamping / Spanngreifer mit senkrechter Bewegung / Pincas pour bridage perpendiculaires / Pinzas perpendiculares para fijación / Pinças pneumáticas perpendiculares para fixação / Chwytyki zaciskowe prostopadłe / Kenetleme için 90° doğrusal tutucular / 垂直气夹 / ワンフィンガー・グリッパー (垂直方向ストローク) / 클램프용 직각 그리퍼

OFFX	F [N]	s [mm]	m [g]
OFFX14-06 <b>NEW</b>	13+63	6	30
OFFX20-10 <b>NEW</b>	20+115	10	65
OFFX30-15 <b>NEW</b>	44+230	15	190
OFFX50-20 <b>NEW</b>	100+900	20	740



Pinze per staffaggio angolari, con dito in plastica / Angular grippers for clamping with finger in polymer / Winkelspanngreifer mit Plastikfinger / Pincas pour bridage angulaires avec doigt en plastique / Pinza mono-dedo neumática para fijación angular / Pinça pneumática mono dedo angular / Chwytyki zaciskowe kątowe z palcem z tworzywa sztucznego / Kenetleme için radyal tutucular / 塑料单指角度夹 / ワンフィンガー・グリッパー (21°開閉、プラスチック爪付) / 폴리머 소재 핑거가 있는 클램프용 앵글러 그리퍼

OFF	C [Ncm]	s	m [g]
OFF20N-20 <b>NEW</b>	100	21°	35
OFF20S-20 <b>NEW</b>	100	21°	35
OFF20V-20 <b>NEW</b>	100	21°	35
OFF20P-20 <b>NEW</b>	100	21°	35
OFF21N-20	100	21°	45
OFF21S-20	100	21°	45
OFF21V-20	100	21°	45
OFF21P-20 <b>NEW</b>	100	21°	45
OFF14P-25 <b>NEW</b>	40	25°	17



O-Ring di ricambio / Spare O-Ring / Ersatz-O-Ring / Joint torique de rechange / Junta tórica de repuesto / O-ring sobressalente / Zapasowa uszczelka O-ring / Yedek O-Ring / 备用O型圈 / 交換用Oリング / 스페어 O-링

OFF		
KIT3-OFP20N	NBR	OFP20N-20 - OFP21N-20
KIT3-OFP20S	Silicone	OFP20S-20 - OFP21S-20
KIT3-OFP20V	Viton	OFP20V-20 - OFP21V-20



Pastiglia di ricambio / Spare pad / Ersatzgummi / Pastille de rechange / Pastilla de recambio / Garra recâmbio / Zapasowa wkładka / Yedek silikon ped / 备用垫 / 効果用パッド / 스페어 패드

OFF		
KIT3-OFP14H <b>NEW</b>	HNBR	OFP14P-25
KIT3-OFP20H <b>NEW</b>	HNBR	OFP20P-20, OFP21P-20
KIT3-OFP20P	TPU	OFP20S-20, OFP21S-20

**Cilindro guidato**  
**Guided cylinder**  
**Geführter Zylinder**  
**Vérin guidé**  
**Cilindro guiado**  
**Cilíndro guiado**  
**Siłownik**  
**Yataklı silindirler**  
**驱动气缸**  
**ガイド付・複動シリンダー**  
**가이드 실린더**



Cilindro a corsa breve / Short stroke cylinder / Kurzhubzylinder / Vérin pneumatique à faible course / Cilindro neumático de carrera corta / Cilindro pneumático de curso curto / Cylinder o małym skoku / Kisa strok silindir / 短行程气缸 / 回り止め付・複動シリンダー (中空ロッド) / 쇼트 스트로크 실린더

OFL	F [N]	s [mm]	m [g]
OFL2010	130	10	60
OFL3015	300	15	110
OFL3030	300	30	140



Cilindro guidato con steli gemellati / Guided cylinder with twin rods / Geführter Zylinder mit doppelseitiger Kolbenstange / Vérin guidé avec tige jumelées / Cilindro guiado de vástagos gemelos / Siłownik z dwoma trzpieniami / Cilindro guiado de dupla haste / Çift millî yataklı silindir / 双杆导向气缸 / 가이드付・複動シリンダー (ダブルロッド) / 트윈 로드가 장착된 가이드 실린더

OFB	F [N]	s [mm]	m [g]
OFB40-A30	660-754	30	475
OFB40-A50	660-754	50	520
OFB40-B30	660-754	30	395
OFB40-B50	660-754	50	445
OFB40-C30	660-754	30	405
OFB40-C50	660-754	50	455



Mini cilindri universali a semplice effetto / General purpose, single-acting mini cylinders / Einfachwirkende Universal-Minizylinder / Mini vérins universels à simple effet / Mini cilindros de simple efecto de propósito universal / Mini cilindros universais de simples efeito / Uniwersalne minicylindry jednokierunkowe / Genel amaçlı tek etkili mini silindir / 单作用通用迷你气缸 / 汎用・単動ミニシリンダー / 일반용, 단일 작동 미니 실린더

OFC	F [N]	s [mm]	m [g]
OFC14-10	4-43	10	20
OFC20-20	8-113	20	40
OFC30-30	23-271	30	85

Accessori / Optionals / Zuberhör / Accessoires / Accesorios / Acessórios / Wyposażenie dodatkowe / Aksesorlar / 配件 / アクセサリー / 선택적

OFC		m [g]
OFC-A001	OFC14-10 - OFC20-20 - OFC30-30	15
OFC-A002	OFC20-20 - OFC30-30	25
OFC-A003	OFC14-10 - OFC20-20 - OFC30-30	15
OFC-A004	OFC20-20 - OFC30-30	25
OFC-A005	OFC14-10 - OFC20-20 - OFC30-30	35
OFC5	OFC20-20 - OFC30-30	40



OFL



OFB

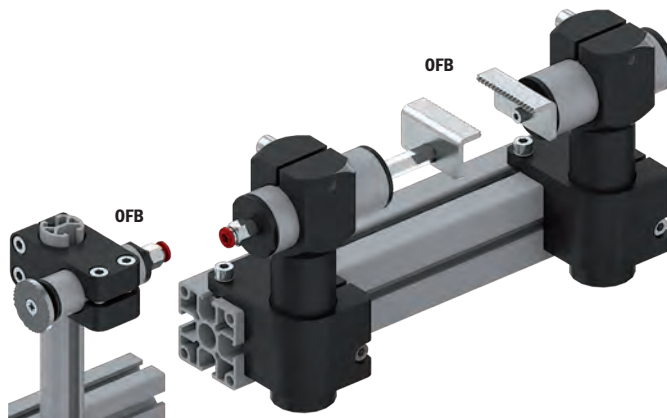

OFB

OFC

Pinze a 2 griffe  
 2-jaw grippers  
 2-Backen-greifer  
 Pincas de 2 mâchoires  
 Pinzas de 2 mordazas  
 Pinças de 2 mordentes  
 Chwytaki 2-szczękowe  
 2 çeneli tutucular  
 双钳口气夹  
 2爪グリッパー  
 2-조 그리퍼



Pinza per agganciamento / Gripper for engagement / Kopplungsgreifer / Doigt de centre / Pinza de bloqueo y centrado / Pinça de Centragem / Chwytak do mocowania / Robot merkezeleme tutucusu / 定位装置 / 位置決め用グリッパー / 인게이지먼트용 그리퍼

AGG	m [g]
AGG19-B	85
AGG21-B	115
AGG21-C	25
AGG30-B	390
AGG30-C	75



Pinze autocentranti per materozze / Self-centering sprue grippers / Selbstzentrierende Angußgreifer / Pincas auto-centrantes pour carottes / Pinza neumática para mazarotas, angular autocentrante / Pinça pneumática angular autocentrada / Samocentrujące chwytaki do wlewków / Merkezlemeli yolluk tutucular / 自动校准气夹 / 自动调芯·スプルーグリッパー / 셀프 센터링 스프루 그리퍼

AA	C [Ncm]	s	m [g]
AA-22	300-300	2x20°	115
AA-22-NO	250-350	2x20°	115
AA-23	300-300	2x20°	100
AA-23-NO	250-350	2x20°	100
AA-26	300-300	2x20°	120
AA-26-NO	250-350	2x20°	120
AA-35	300-300	2x20°	140
AA-35-NO	250-350	2x20°	140



Pinze non autocentranti per materozze / Non-self-centering sprue grippers / Nichtselbstzentrierende Angußgreifer / Pincas non auto-centrantes pour carottes / Pinza neumática angular no autocentrante para mazarotas / Pinça pneumática angular não auto-centrada para gítos / Chwytaki do wlewków bez funkcji samocentrowania / Merkezlemesiz yolluk tutucular / 非自动校准气夹 / 非自动调芯·스프ルーグリッパー / 셀프 센터링이 아닌 스프루 그리퍼

PB	C [Ncm]	s	m [g]
PB-0008	48	2x10°	15
PB-0009	48	2x10°	25
PB-0013	160	2x15°	55
PB-0014	160	2x15°	50
PB-0015	120-50	2x16°	50
PB-0017	160	2x15°	45
PB-0140	160	2x15°	75
PB-0150	160	2x15°	75
PB-0160	160	2x15°	75
PB-0170	160	2x15°	50
PB-0180	160	2x15°	60
PB-0181	160	2x15°	75
PB-0182	160	2x15°	75
PB-0187	160	2x15°	57



Pinze non autocentranti per materozze / Non-self-centering sprue grippers / Nichtselbstzentrierende Angußgreifer / Pincas non auto-centrantes pour carottes / Pinza para mazarotas no autocentrante / Pinça não autocentrada para gítos / Chwytaki do wlewków bez funkcji samocentrowania / Merkezlemesiz yolluk tutucular / 非自动校准气夹 / 非自动调芯·스프ルーグリッパー / 셀프 센터링이 아닌 스프루 그리퍼

BB	C [Ncm]	s	m [g]
BB-12-00	130-40	2x15°	75
BB-12-NO	120	2x15°	77
BB-13-NO	120	2x15°	90



Pinza pneumatica per materozze, angolare autocentrante a due griffe / 2-jaw self-centering angular pneumatic sprue gripper / Selbstzentrierende pneumatische Anguss-Winkelgreifzangen mit 2 Backen / Pince pneumatique angulaire auto-centreuse / Pinza neumática angular para mazarotas, autocentrante de dos dedos / Pinça pneumática angular autocentrada de dois dedos / 2-szczękowy samocentrujący, kątowny chwytak wlewka / Merkezlemeli yolluk tutucular / 双钳口自动校准角度气夹 / 自动调芯·2爪エアーグリッパー / 2-조 셀프 센터링 앵글러 공압 스프루 그리퍼

DD	C [Ncm]	s	m [g]
DD20-16R	600	2x15°	165
DD20-16RS	600	2x15°	190
DD20-16P	600	2x15°	160
DD20-16PS	600	2x15°	195
DD20-16E	600	2x15°	165
DD20-16ES	600	2x15°	200
DD20-16K	600	2x15°	170
DD20-16KS	600	2x15°	200
DD20-16A	600	2x15°	135
DD20-16AS	600	2x15°	175
DD20-16M	600	2x15°	165
DD20-16W	600	2x15°	170
DD20-16L	600	2x15°	160

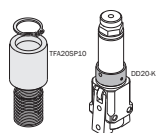

Kit opzionale per la sospensione / Optional suspension kit / Kit für die Aufhängung optional / Kit pour suspension optionnel / Kit opcional para la suspensión / Kit opcional para a suspensão / Opcja dodatkowa - zestaw do zawieszania / Opsiyonel süspaniyon kit / 可选的悬吊组件 / サスペンションキット / 선택적 서스펜션 키트

DD	m [g]
DD20-K1	5
TFA20SP10	85

Pinze a 2 griffe  
2-jaw grippers  
2-Backen-greifer  
Pincas à 2 mâchoires  
Pinzas de 2 mordazas  
Pinças de 2 mordentes  
Chwytaki 2-szczękowe  
2 çeneli tutucular  
双钳口气夹  
2爪グリッパー  
2-조 그리퍼



Pinze universali / Universal grippers / Universalgreifer / Pincas universelles / Pinzas universales / Pinças universais / Chwytaki uniwersalne / 2 çeneli paralel tutucular / 通用气夹 / 汎用平行グリッパー / 범용 그리퍼

GS	F [N]	s [mm]	m [g]
GS-10	28-36	2x2.3	45
GS-10-NC	40-24	2x2.3	45
GS-10-NO	18-46	2x2.3	45
GS-16	86-100	2x3.4	98
GS-16-NC	116-70	2x3.4	99
GS-16-NO	60-126	2x3.4	99
GS-20	186-212	2x5.2	207
GS-20-NC	228-170	2x5.2	209
GS-20-NO	134-264	2x5.2	209
GS-25	254-282	2x7.2	365
GS-25-NC	(3)	2x7.2	(3) (2)
GS-25-NO	190-346	2x7.2	369
GS-32	NEW 430-500	2x11	645
GS-32-NC	(3)	2x11	(3) (2)
GS-32-NO	(3)	2x11	(3) (2)
GS-40	NEW 614-700	2x15	1155
GS-40-NC	(3)	2x15	(3) (2)
GS-40-NO	(3)	2x15	(3) (2)



Pinza pneumatica a 2 griffe ad azione parallela autocentrante / 2-jaw parallel-acting self-centering pneumatic gripper / Selbstzentrierender, pneumatischer 2-Backen-Parallelgreifer Baureihe / Pince pneumatique parallèle auto-centreuse / Pinza neumática de 2 dedos con acción paralela autocentrante / Pinça pneumática de dois dedos com acção paralela de auto-centragem / 2-szczękowy, równoległy, samocentrujący chwytak pneumatyczny / Ayarlanabilir sensör girişli / 双钳口自动校准平行气夹 / 自動調芯・2爪平行開閉型エアグリッパー / 2-조 평행 작동 셀프 센터링 공압 그리퍼

SGP-S	F [N]	s [mm]	m [g]
SGP-20S	40-46	2x2	33
SGP-25S	94-104	2x3	43
SGP-32S	120-134	2x4	86
SGP-40S	146-160	2x6	170

(2)  
Articolo disponibile a richiesta, non gestito a magazzino / Item available upon request, not in stock / Artikel auf Wunsch lieferbar, nicht am Lager / Article disponible sur demande, non géré par le magasin / Artículo disponible bajo pedido, no gestionado en el almacén / Artigo disponível mediante solicitação, ausente do armazém / Pozycja dostępna na zamówienie - brak w magazynie / İstek üzerine hazir edilir. Stokta bulunmaz / 产品根据要求定制, 不做库存 / 受注生産品 (通常在庫品ではありません) 。 / 요청에 따라 사용 가능한 품목, 재고 없음

(3)  
Consultare il fabbricante / Consult Factory / Fragen Sie den Hersteller / Consulter l'usine / Consulte con el fabricante / Consultar a fábrica / Skontaktować się z producentem / Fabrikaya danışınız / 咨询厂家 / 弊社までお問合せ下さい。 / 컨설트 팩토리



SZ	F [N]	s [mm]	m [g]
SZ12	50	2x4	94
SZ12-NC	(3)	2x4	(3) (2)
SZ16	90	2x6	153
SZ16-NC	(3)	2x6	(3) (2)
SZ25	230	2x10	446
SZ25-NC	(3)	2x10	(3) (2)
SZ32	380	2x12.5	722
SZ32-NC	(3)	2x12.5	(3) (2)
SZ40	620	2x15	1135
SZ40-NC	(3)	2x15	(3) (2)



Corsa lunga / Long stroke / Langer Hub / Course longue / Carrera larga / Curso longo / Duzgi skok / Uzun Strok / 长行程 / 롱스트로크 / 긴 스트로크

PQ	F [N]	s [mm]	m [g]
PQ1608	120	2x4	63
PQ2012	180	2x6	110
PQ2516	300	2x8	200
PQ3015	400	2x7.5	330
PQ3523	560	2x11.5	610
PQ4533	920	2x16.5	1270
PQ5047	1340	2x23.5	2430
PQ6063	1860	2x31.5	4900



Pinza ad aghi / Needle gripper / Nadelgreifer / Pincas à aiguilles / Pinça de agulhas / Pince à aiguilles / Chwytak igłowy / İğneli tutucular / 针爪 / 니들 / 니들 / 그리퍼

PT25	F [N]	s [mm]	m [g]
PT25	90	2x7	165

Pinze a 2 griffe  
2-jaw grippers  
2-Backen-greifer  
Pincas de 2 mâchoires  
Pinzas de 2 mordazas  
Pinças de 2 mordentes  
Chwytyki 2-szczękowe  
2 çeneli tutucular  
双钳口气夹  
2爪グリッパ  
2-조 그리퍼



Pinze universali / Universal grippers / Universalgreifer / Pincas universelles / Pinzas universales / Pinças universais / Chwytyki uniwersalne / 2 çeneli açılı tutucular / 通用气夹 / 汎用平行グリッパ / 범용 그리퍼

GW	C [Ncm]	s	m [g]
<b>GW-10</b>	16-22	2x20°	39
GW-10-NC	(3)	2x20°	(3) (2)
<b>GW-10-NO</b>	8-30	2x20°	39
<b>GW-16</b>	72-90	2x20°	88
<b>GW-16-NC</b>	36-66	2x20°	89
<b>GW-16-NO</b>	48-114	2x20°	89
<b>GW-20</b>	156-178	2x20°	171
GW-20-NC	(3)	2x20°	(3) (2)
<b>GW-20-NO</b>	104-230	2x20°	173
<b>GW-25</b>	320-356	2x20°	300
GW-25-NC	(3)	2x20°	(3) (2)
GW-25-NO	(3)	2x20°	(3) (2)

(2)

Articolo disponibile a richiesta, non gestito a magazzino / Item available upon request, not in stock / Artikel auf Wunsch lieferbar, nicht am Lager / Article disponible sur demande, non géré par le magasin / Artículo disponible bajo pedido, no gestionado en el almacén / Artigo disponível mediante solicitação, ausente do armazém / Pozycja dostępna na zamówienie – brak w magazynie / İstek üzerine hazır edilir, Stokta bulunmaz / 产品根据要求定制, 不做库存 / 受注生産品 (通常在庫品ではありません) 。 / 요청에 따라 사용 가능한 품목, 재고 없음

(3)

Consultare il fabbricante / Consult Factory / Fragen Sie den Hersteller / Consulter l'usine / Consulte con el fabricante / Consultar a fábrica / Skontaktować się z producentem / Fabrikaya danışınız / 咨询厂家 / 弊社までお問合せ下さい。 / 컨설트 팩토리



Mini pinza angolare a due griffe autocentrante / 2-jaw self-centering angular mini gripper / Selbstzentrierende Mini-Winkelgreifer mit zwei Backen / Mini pince angulaire à deux mâchoires auto-centrante / Mini pinza angular autocentrante de dos dedos / Mini pinça angular com dois dedos autocentrados / 2-szczękowy samocentryjący minichwytyk kątowy / 2 çeneli açılı mini tutucular / 双钳口自动校准迷你型角度夹 / 自動調芯・2爪支点開閉型ミニグリッパ / 2-조 셀프 센터링 앵글러 미니 그리퍼

TFA	C [Ncm]	s	m [g]
<b>TFA10-25</b>	34	2x12.5°	12
<b>TFA14-25</b>	96	2x12.5°	30
<b>TFA20-25</b>	430	2x12.5°	95
<b>TFA20-25S</b>	430	2x12.5°	120



Kit opzionale per la sospensione / Optional suspension kit / Kit für die Aufhängung optional / Kit pour suspension optionnel / Kit opcional para la suspensión / Kit opcional para a suspensão / Opcja dodatkowa – zestaw do zawieszenia / Opsiyonel süspansiyon kit / 可选的悬件组件 / サスペンションキット / 선택적 서스펜션 키트

TFA	m [g]
<b>TFA10SP05</b>	10
<b>TFA14SP05</b>	35
<b>TFA20SP10</b>	85

Pinze ad espansione  
Air hands  
ID Innengreifer  
Préhenseurs intérieurs  
Pinzas de expansión  
Pegas interiores  
Chwytaki wysuwne  
Hassas taşıyıcı  
膨胀气夹  
バルーングリッパー  
에어 핸드

L MFD...CL MFD...HL

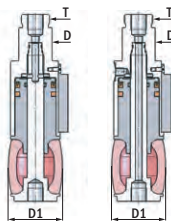

MFD	T	D [mm]	D1 [mm]	m [g]
MFD08S01CL	M12x1	Ø14	Ø8+Ø11	15
MFD08E02CL	M12x1	Ø14	Ø8+Ø11	15
MFD08S01HL	M12x1	Ø14	Ø8+Ø11	15
MFD08E02HL	M12x1	Ø14	Ø8+Ø11	15
MFD10S01CL	M12x1	Ø14	Ø10.5+Ø14	16
MFD10E02CL	M12x1	Ø14	Ø10.5+Ø14	16
MFD10S01HL	M12x1	Ø14	Ø10.5+Ø14	16
MFD10E02HL	M12x1	Ø14	Ø10.5+Ø14	16
MFD12S01CL	M12x1	Ø14	Ø13+Ø17	17
MFD12E02CL	M12x1	Ø14	Ø13+Ø17	17
MFD12S01HL	M12x1	Ø14	Ø13+Ø17	17
MFD12E02HL	M12x1	Ø14	Ø13+Ø17	17
MFD14S01CL	M12x1	Ø14	Ø15+Ø19.5	17
MFD14E02CL	M12x1	Ø14	Ø15+Ø19.5	17
MFD14S01HL	M12x1	Ø14	Ø15+Ø19.5	17
MFD14E02HL	M12x1	Ø14	Ø15+Ø19.5	17
MFD16S01CL	M12x1	Ø14	Ø17+Ø21	17
MFD16E02CL	M12x1	Ø14	Ø17+Ø21	17
MFD16S01HL	M12x1	Ø14	Ø17+Ø21	17
MFD16E02HL	M12x1	Ø14	Ø17+Ø21	17
MFD18S01CL	M12x1	Ø14	Ø19.5+Ø24.5	28
MFD18E02CL	M12x1	Ø14	Ø19.5+Ø24.5	28
MFD18S01HL	M12x1	Ø14	Ø19.5+Ø24.5	28
MFD18E02HL	M12x1	Ø14	Ø19.5+Ø24.5	28
MFD22S01CL	M12x1	Ø14	Ø24+Ø31.5	43
MFD22E02CL	M12x1	Ø14	Ø24+Ø31.5	43
MFD22S01HL	M12x1	Ø14	Ø24+Ø31.5	43
MFD22E02HL	M12x1	Ø14	Ø24+Ø31.5	43
MFD27S01CL	M17x1	Ø20	Ø28+Ø37	79
MFD27E02CL	M17x1	Ø20	Ø28+Ø37	79
MFD27S01HL	M17x1	Ø20	Ø28+Ø37	79
MFD27E02HL	M17x1	Ø20	Ø28+Ø37	79
MFD33S01CL	M17x1	Ø20	Ø34+Ø45	118
MFD33E02CL	M17x1	Ø20	Ø34+Ø45	118
MFD33S01HL	M17x1	Ø20	Ø34+Ø45	118
MFD33E02HL	M17x1	Ø20	Ø34+Ø45	118
MFD41S01CL	M27x1	Ø30	Ø42+Ø54	280
MFD41E02CL	M27x1	Ø30	Ø42+Ø54	280
MFD41S01HL	M27x1	Ø30	Ø42+Ø54	280
MFD41E02HL	M27x1	Ø30	Ø42+Ø54	280
MFD47S01CL	M27x1	Ø30	Ø48+Ø60	280
MFD47E02CL	M27x1	Ø30	Ø48+Ø60	280
MFD47S01HL	M27x1	Ø30	Ø48+Ø60	280
MFD47E02HL	M27x1	Ø30	Ø48+Ø60	280
MFD51S01CL	M27x1	Ø30	Ø54+Ø68	490
MFD51E02CL	M27x1	Ø30	Ø54+Ø68	490
MFD51S01HL	M27x1	Ø30	Ø54+Ø68	490
MFD51E02HL	M27x1	Ø30	Ø54+Ø68	490
MFD63S01CL	M27x1	Ø30	Ø66+Ø85	800
MFD63E02CL	M27x1	Ø30	Ø66+Ø85	800
MFD63S01HL	M27x1	Ø30	Ø66+Ø85	800
MFD63E02HL	M27x1	Ø30	Ø66+Ø85	800

MFU...CL MFU...HL

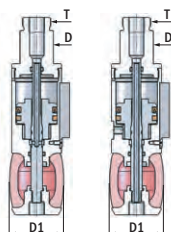

MFU	T	D [mm]	D1 [mm]	m [g]
MFU08S01CL	M12x1	Ø14	Ø8+Ø11	16
MFU08E02CL	M12x1	Ø14	Ø8+Ø11	16
MFU08S01HL	M12x1	Ø14	Ø8+Ø11	16
MFU08E02HL	M12x1	Ø14	Ø8+Ø11	16
MFU10S01CL	M12x1	Ø14	Ø10.5+Ø14	17
MFU10E02CL	M12x1	Ø14	Ø10.5+Ø14	17
MFU10S01HL	M12x1	Ø14	Ø10.5+Ø14	17
MFU10E02HL	M12x1	Ø14	Ø10.5+Ø14	17
MFU12S01CL	M12x1	Ø14	Ø13+Ø17	18
MFU12E02CL	M12x1	Ø14	Ø13+Ø17	18
MFU12S01HL	M12x1	Ø14	Ø13+Ø17	18
MFU12E02HL	M12x1	Ø14	Ø13+Ø17	18
MFU14S01CL	M12x1	Ø14	Ø15+Ø19.5	20
MFU14E02CL	M12x1	Ø14	Ø15+Ø19.5	20
MFU14S01HL	M12x1	Ø14	Ø15+Ø19.5	20
MFU14E02HL	M12x1	Ø14	Ø15+Ø19.5	20
MFU16S01CL	M12x1	Ø14	Ø17+Ø21	20
MFU16E02CL	M12x1	Ø14	Ø17+Ø21	20
MFU16S01HL	M12x1	Ø14	Ø17+Ø21	20
MFU16E02HL	M12x1	Ø14	Ø17+Ø21	20
MFU18S01CL	M12x1	Ø14	Ø19.5+Ø24.5	35
MFU18E02CL	M12x1	Ø14	Ø19.5+Ø24.5	35
MFU18S01HL	M12x1	Ø14	Ø19.5+Ø24.5	35
MFU18E02HL	M12x1	Ø14	Ø19.5+Ø24.5	35
MFU22S01CL	M12x1	Ø14	Ø24+Ø31.5	50
MFU22E02CL	M12x1	Ø14	Ø24+Ø31.5	50
MFU22S01HL	M12x1	Ø14	Ø24+Ø31.5	50
MFU22E02HL	M12x1	Ø14	Ø24+Ø31.5	50
MFU27S01CL	M17x1	Ø20	Ø28+Ø37	100
MFU27E02CL	M17x1	Ø20	Ø28+Ø37	100
MFU27S01HL	M17x1	Ø20	Ø28+Ø37	100
MFU27E02HL	M17x1	Ø20	Ø28+Ø37	100
MFU33S01CL	M17x1	Ø20	Ø34+Ø45	130
MFU33E02CL	M17x1	Ø20	Ø34+Ø45	130
MFU33S01HL	M17x1	Ø20	Ø34+Ø45	130
MFU33E02HL	M17x1	Ø20	Ø34+Ø45	130
MFU41S01CL	M27x1	Ø30	Ø42+Ø54	300
MFU41E02CL	M27x1	Ø30	Ø42+Ø54	300
MFU41S01HL	M27x1	Ø30	Ø42+Ø54	300
MFU41E02HL	M27x1	Ø30	Ø42+Ø54	300
MFU47S01CL	M27x1	Ø30	Ø48+Ø60	300
MFU47E02CL	M27x1	Ø30	Ø48+Ø60	300
MFU47S01HL	M27x1	Ø30	Ø48+Ø60	300
MFU47E02HL	M27x1	Ø30	Ø48+Ø60	300
MFU51S01CL	M27x1	Ø30	Ø54+Ø68	500
MFU51E02CL	M27x1	Ø30	Ø54+Ø68	500
MFU51S01HL	M27x1	Ø30	Ø54+Ø68	500
MFU51E02HL	M27x1	Ø30	Ø54+Ø68	500
MFU63S01CL	M27x1	Ø30	Ø66+Ø85	785
MFU63E02CL	M27x1	Ø30	Ø66+Ø85	785
MFU63S01HL	M27x1	Ø30	Ø66+Ø85	785
MFU63E02HL	M27x1	Ø30	Ø66+Ø85	785



Pinze ad espansione  
Air hands  
ID Innengreifer  
Préhenseurs intérieurs  
Pinzas de expansión  
Pegas interiores  
Chwytki wysuwne  
Hassas taşıyıcı  
膨胀气夹  
バルーングリッパー  
에어 핸드

## MFD-MFU

Accessori / Optionals / Zuberhör / Accessoires / Accesorios / Acessórios /  
Wyposażenie dodatkowe / Aksesuarlar / 配件 / アクセサリー / 선택적



Ricambio per la parte elastica in EPDM / Spare for the elastic part in EPDM / Ersatzteil für das dehnbare Element EPDM / Pièce de rechange pour la partie élastique en EPDM / Recambio para la pieza elástica de EPDM / Peça sobressalente para a parte elástica em EPDM / Rezerwa dla części elastycznej z EPDM / Yedek elastik parça EPDM / EPDM制的备用部件 / 交換用EPDMゴム / EPDM 내 탄성 부품용 예비 부품

	MFD	m
	MFU	[g]
IF08E02	Ø8	1
IF10E02	Ø10	1
IF12E02U	Ø12	1
IF14E02U	Ø14	1
IF16E02U	Ø16	2
IF18E02	Ø18	3
IF22E02	Ø22	5
IF27E02	Ø27	8
IF33E02	Ø33	15
IF41E02	Ø41	30
IF47E02U	Ø47	35
IF51E02	Ø51	56
IF63E02	Ø63	108



Coni di centraggio / Centering cones / Zentrierkonen / Cônes de centrage / Conos de centrado / Cones de centragem / Stożki centrujące / Merkezleme Konisi / 对准椎体 / 位置決め用・先端コーン / 센터링 콘

	MFD	m
	MFU	[g]
MFC10	Ø10	0.5
MFC12	Ø12	1
MFC14	Ø14 - Ø16	1
MFC18	Ø18	1.5
MFC22	Ø22	2
MFC27	Ø27	5
MFC33	Ø33	7
MFC41	Ø41 - Ø47	12
MFC51	Ø51	21
MFC63	Ø63	30

## MFD-MFU

Accessori / Optionals / Zuberhör / Accessoires / Accesorios / Acessórios /  
Wyposażenie dodatkowe / Aksesuarlar / 配件 / アクセサリー / 선택적



Ricambio per la parte elastica in Silicone / Spare for the elastic part in silicone / Ersatzteil für das dehnbare Element aus Silikon / Pièce de rechange pour la partie élastique en silicone / Recambio para la pieza elástica de silicona / Peça sobressalente para a parte elástica em silicone / Rezerwa dla części elastycznej z silikonowa / Yedek elastik parça silikon / 备用硅胶圈 / 交換用シリコンゴム / 실리콘으로 된 탄성 부품용 예비 부품

	MFD	m
	MFU	[g]
IF08S01	Ø8	1
IF10S01	Ø10	1
IF12S01U	Ø12	1
IF14S01U	Ø14	1
IF16S01U	Ø16	2
IF18S01	Ø18	3
IF22S01	Ø22	5
IF27S01	Ø27	8
IF33S01	Ø33	15
IF41S01	Ø41	30
IF47S01U	Ø47	35
IF51S01	Ø51	56
IF63S01	Ø63	124



Basette porta sensori / Sensor holders / Sensorhalter / Support pour capteurs / Soportes portasensores / Suporte para sensores / Uchwyty czujników / Sensör braket / 传感器支架 / 센서 고정용ホル더 / 센서 홀더

		m
		[g]
MFD27-K	MFD	Ø27 4
MFU27-K	MFU	Ø27 4
MFD33-K	MFD	Ø33 5
MFU33-K	MFU	Ø33 5
MFD41-K	MFD	Ø41 - Ø47 5
MFU41-K	MFU	Ø41 - Ø47 5
MFD51-K	MFD	Ø51 6
MFU51-K	MFU	Ø51 6
MFD63-K	MFD	Ø63 7
MFU63-K	MFU	Ø63 7

Pinze ad espansione  
 Air hands  
 ID Innengreifer  
 Préhenseurs intérieurs  
 Pinzas de expansión  
 Pegas interiores  
 Chwytki wysuwne  
 Mikro Hassas taşıyıcılar  
 膨胀气夹  
 バルーングリッパー  
 에어 핸드

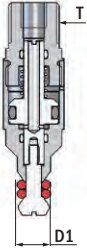

IFU...RT	T	D1 [mm]	m [g]
IFU04S01RT	M10x1	Ø4.5÷Ø5.4	7
IFU04N03RT	M10x1	Ø4.5÷Ø5.4	7
IFU05S01RT	M10x1	Ø5.6÷Ø6.7	7
IFU05N03RT	M10x1	Ø5.6÷Ø6.7	7
IFU06S01RT	M10x1	Ø6.6÷Ø7.6	8
IFU06N03RT	M10x1	Ø6.6÷Ø7.6	8
IFU07S01RT	M10x1	Ø7.6÷Ø8.7	9
IFU07N03RT	M10x1	Ø7.6÷Ø8.7	9

### IFU-RT

Accessori / Optionals / Zuberhör / Accessoires / Accesorios / Acessórios /  
 Wyposażenie dodatkowe / Aksesuarlar / 配件 / アクセサリー / 선택적



Ricambio per la parte elastica in NBR / Spare for the elastic part in NBR / Ersatzteil für das dehnbare Element aus NBR / Pièce de rechange pour la partie élastique en NBR / Recambio para la pieza elástica de NBR / Peça sobressalente para a parte elástica em NBR / Rezerwa dla części elastycznej z NBR / Yedek elastik parça NBR / NBR制的备用部件 / 交換用NBRゴム / NBR에 있는 탄성 부품용 예비 부품

	IFU	m [g]
IF04N03	Ø4	1
IF05N03	Ø5	1
IF06N03	Ø6	1
IF07N03	Ø7	1



Ricambio per la parte elastica in Silicone / Spare for the elastic part in silicone / Ersatzteil für das dehnbare Element aus Silikon / Pièce de rechange pour la partie élastique en silicone / Recambio para la pieza elástica de silicona / Peça sobressalente para a parte elástica em silicone / Rezerwa dla części elastycznej silikonowa / Yedek elastik parça silikon / 备用硅胶圈 / 交換用シリコンゴム / 실리콘으로 된 탄성 부품용 예비 부품

	IFU	m [g]
IF04S01	Ø4	1
IF05S01	Ø5	1
IF06S01	Ø6	1
IF07S01	Ø7	1

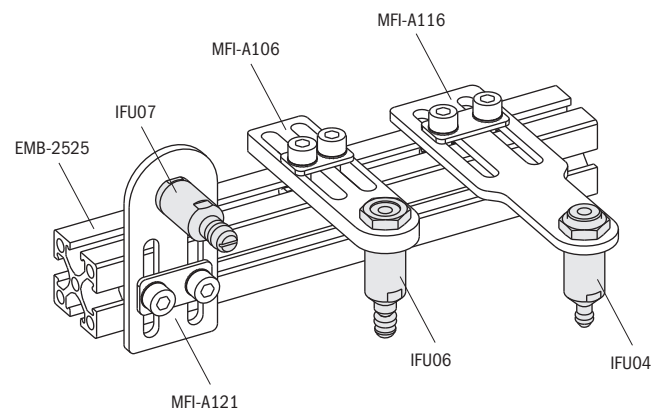

Taglierini pneumatici  
Air nipper  
Pneumatische Schneidzangen  
Pincas coupantes pneumatiques  
Tijeras neumática  
Tesouras pneumática  
Szczypce tnące pneumatyczne  
Pnömatik kesiciler  
气动剪钳  
エアニッパー  
에어 니퍼



Attuatori pneumatici per taglierini / Air nipper actuators / Pneumatische Schneidzangen / Pincas coupe-carotte pneumatiques / Actuadores neumáticos para tijeras / Actuador pneumático para tesoura / Siłowniki pneumatyczne dla szczypiec tnących / GN serisi pnömatik kesici / 气动剪钳执行器 / 에어니ッパー액츄에이터 / 에어 니퍼 액츄에이터

GN	C [Nm]	s	m [g]
GN-05	22	2x7°	102
GN-05S	22	2x7°	125
GN-10	76	2x5°	157
GN-10S	76	2x5°	208
GN-20	134	2x7°	263
GN-20S	134	2x7°	370
GN-30	300	2x7.5°	480
GN-30S	300	2x7.5°	715
GN-50	232	2x12°	1100
GN-50S	232	2x12°	1440



Attuatori pneumatici per taglierini / Air nipper actuators / Pneumatische Schneidzangen / Pincas coupe-carotte pneumatiques / Actuadores neumáticos para cortadores / Actuadores pneumáticos / Siłowniki pneumatyczne dla szczypiec tnących / GNS serisi pnömatik kesici / 气动剪钳执行器 / 에어니ッパー액츄에이터 / 에어 니퍼 액츄에이터

GNS	C [Nm]	s	m [g]
GNS-05	28	2x5°	112
GNS-05-NC	28	2x5°	180
GNS-05-NO	28	2x5°	175
GNS-10	68	2x5°	355
GNS-10-NC	68	2x5°	570
GNS-10-NO	68	2x5°	570
GNS-20	84	2x9°	480
GNS-20-NC	84	2x9°	780
GNS-20-NO	84	2x9°	780



Slitte per GN / Slides for GN / Schlitten für GN / Glissières pour GN / Unidad de guiado para GN / Suporte com deslocamento para GN / Prowadnice ślizgowe dla GN / Kesiciler için pnömatik kızak / GN滑軌 / 에어니ッパーGN用・エアースライド / GN용 핑거

ZG	F [N]	s [mm]	m [g]
ZG-16-NO	65-135	10	180
ZG-16S-NO	65-135	10	200
ZG-16-NC	120-80	10	180
ZG-16S-NC	120-80	10	200
ZG-25-NO	210-300	10	360
ZG-25S-NO	210-300	10	425
ZG-25-NC	275-240	10	360
ZG-25S-NC	275-240	10	425



Lame per taglierini pneumatici / Blades for air nippers / Schneideinsätze für pneumatische Schneidzangen / Lames pour tronçonneuses pneumatiques / Cuchillas para actuadores neumáticos / Láminas para actuadores pneumáticos / Ostrza do szczypiec tnących pneumatycznych / Standart bıçaklar / 气动剪钳刀片 / 에어니ッパー用・刃物 / 에어 니퍼용 블레이드

G.N	m [g]
G.N5AJ	33
G.N5AP	34
G.N5PF	35
G.N10LAJ	117
G.N10LAP	115
G.N10LPF	112
G.N20AJ	121
G.N20AP	120
G.N20PF	124
G.N20AJL	220
G.N30AJ	365
G.N30AP	380
G.N30PF	388
G.N10LAB152	165
G.N20AB360	185
G.N30AA114	385
G.N30AA	390
G.N20ALLL	190
G.N30FAL	455
G.N10LAE269	120
G.N20AE	135
G.N30AE	395



Griffe per GN / Fingers for GN / Spannbacken für GN / Mâchoires pour GN / Dedos para actuadores neumáticos serie GN / Dedos para actuadores pneumáticos série GN / Szczęki dla GN / Gn için parmaklar / GN气夹 / 에어니ッパーGN用・爪 / GN용 핑거

JG	m [g]
JGW-10S-A50	175
JGW-20S-A50	185
JGN-10S-A52	190
JGN-20S-A52	200



Slitte a doppia corsa / Double stroke slide / Schlitten mit Doppelhub / Glissières à double course / Carro guiado de doble recorrido / Corrediza de duplo curso / Prowadnice ślizgowe dwukierunkowe / Çift stroklu kızak / 双行程滑軌 / 스피어그리пп어用・多段エアースライド / 더블 스트로크쪽

ZJ	F [N]	s [mm]	m [g]
ZJ-3235	450	35	1330

**Taglierini pneumatici**  
**Air nipper**  
**Pneumatische Schneidzangen**  
**Pinces coupantes pneumatiques**  
**Tijeras neumática**  
**Tesouras pneumática**  
**Szczypce tnące pneumatyczne**  
**PNömatik kesiciler**  
**气动剪钳**  
**エア-ニッパー**  
**에어 니퍼**

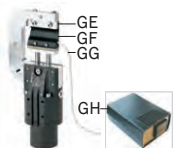

Taglierini a ghigliottina / Thrust Cut Nippers / Angusschneidezange Guillotine / Pinces coupantes à guillotine / Guillotinas / Szczypce tnące – gilotyna / Basınçlı sıcak kesme makasları / 推入式剪钳 / スラストカットニッパー / 추진력 차단 니퍼

GN-	F	s	m
	[N]	[mm]	[g]
GN-240	1470	20	1330
GN-263	3648	32	2900

#### GN-

Accessori / Optionals / Zuberhör / Accessoires / Accesorios / Acessórios /  
 Wyposażenie dodatkowe / Aksesuarlar / 配件 / アクセサリー / 선택적

Lame di ricambio / Spare blade / Ersatzschneideinsätze / Lames de rechange /  
 Cuchilla de recambio / Lâmina sobresselente / Zapasowe ostrze / Yedek bıçak / 备用  
 刀片 / 交換用·刃物 / 스페어 블레이드

5620 (GE)	GN-240
5619 (GF)	GN-240
5617 (GE)	GN-263
5616 (GF)	GN-263

Resistenza + Termocoppia / Cartridge + thermocouple / Heizpatrone + Thermopaar /  
 Résistance + Thermocouple / Resistencia + termopar / Resistência + sonda / Wkład  
 i termopara / Rezistans + Termokupl / 电阻+热电偶 / 히터+及ヒ熱電対 / 카트리지  
 + 열전대

R50-G (GG)	GN-240
R75-G (GG)	GN-263

Termoregolatore / Heater control box / Temperaturregler / Thermorégulateur /  
 Regulador de temperatura / Termoregulador / Regulator temperatury / Isı kontrol  
 kutusu / 加热器控制箱 / 히터-용·温度調節ボックス / 히터 제어 상자

CH102-G (GH)	GN-240, GN-263
--------------	----------------



Portalama / Blade holder / Klingenhalter / Porte-lame / Porta-cuchilla / Suporte de  
 lâmina / Uchwyt ostrza / Bıçak tutucu / 刀架 / 刃物付ホルダー / 블레이드 홀더

GNB	NEW	m
		[g]
GNB-2045		200



GN-240

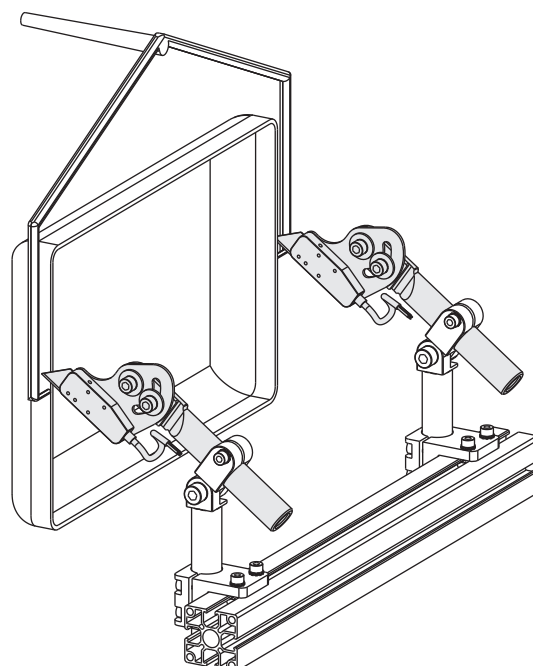

Ventose  
 Vacuum cups  
 Saugnäpfe  
 Ventouses  
 Ventosas  
 Ventosas  
 Przyssawki  
 Vantuzlar  
 真空吸盘  
 真空カップ  
 진공 컵



Ventose plane / Flat vacuum cups / Flachsaugnäpfe / Ventouses plates / Ventosa plana / Ventosas esféricas / Przyssawki płaskie / Düz vantuz / 真空吸盘 / 平型・真空カップ / 플랫폼 진공컵

V01	P/G	GL [mm]	m [g]
V0111S01	P	Ø11	0.6
V0111E02	P	Ø11	0.6
V0111R03	P	Ø11	0.6
V0111H04	P	Ø11	0.6
V0116S01	P	Ø16.2	0.6
V0116E02	P	Ø16.2	0.6
V0116R03	P	Ø16.2	0.6
V0116H04	P	Ø16.2	0.6
V0122S01	G	Ø22	1.3
V0122E02	G	Ø22	1.2
V0122R03	G	Ø22	1.2
V0122H04	G	Ø22	1.2
V0133S01	G	Ø32	2.7
V0133E02	G	Ø32	2.6
V0133R03	G	Ø32	2.7
V0133H04	G	Ø32	2.7
V0142S01	G	Ø41	4.8
V0142E02	G	Ø41	4.6
V0142R03	G	Ø41	4.7
V0142H04	G	Ø41	4.7
V0153S01	G	Ø51.4	8.9
V0153E02	G	Ø51.4	8.4
V0153R03	G	Ø51.4	8.6
V0153H04	G	Ø51.4	8.6



Nippli / Nipples / Nippel / Mamelons / Niples / Acessórios de ventosa / Złączeni / Nipeller / 螺母 / 니플러 / 니플

AV	P/G	GO [mm]	m [g]
AV01M5F08	P	M5	1.2
AV0118F13	P	G1/8"	4
AV0118F12	G	G1/8"	3
AV0118F16	G	G1/8"	6.2
AV0114F16	G	G1/4"	4.6

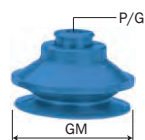

Ventose a soffierto / Bellow vacuum cups / Balgsaugnäpfe / Ventouses à soufflet / Ventosa con fuelle / Ventosas com fole / Przyssawki z mieszkim / Körüklü vantuz / 多层真空吸盘 / 베로-型・真空カップ / 벨로우 진공컵

V02	P/G	GM [mm]	m [g]
V0211S01	P	Ø11	0.8
V0211E02	P	Ø11	0.8
V0211R03	P	Ø11	0.8
V0211H04	P	Ø11	0.8
V0216S01	P	Ø15.7	1.3
V0216E02	P	Ø15.7	1.2
V0216R03	P	Ø15.7	1.2
V0216H04	P	Ø15.7	1.2
V0222S01	P	Ø22	1.7
V0222E02	P	Ø22	1.6
V0222R03	P	Ø22	1.6
V0222H04	P	Ø22	1.6
V0233S01	G	Ø34	5.3
V0233E02	G	Ø34	5
V0233R03	G	Ø34	5.1
V0233H04	G	Ø34	5.1
V0242S01	G	Ø42	8.6
V0242E02	G	Ø42	8.2
V0242R03	G	Ø42	8.4
V0242H04	G	Ø42	8.4
V0253S01	G	Ø53	14.8
V0253E02	G	Ø53	14
V0253R03	G	Ø53	14.4
V0253H04	G	Ø53	14.4



















Nippli / Nipples / Nippel / Mamelons / Niples / Acessórios de ventosa / Złączeni / Nipeller / 螺母 / 니플러 / 니플

AV	P/G	GQ [mm]	m [g]
AV01M5M08	P	M5	0.8
AV0118M12	G	G1/8"	3.6
AV0118M13	P	G1/8"	4
AV0118M16	G	G1/8"	4
AV0114M16	G	G1/4"	5.4

Ventose  
 Vacuum cups  
 Saugnäpfe  
 Ventouses  
 Ventosas  
 Ventosas  
 Przyssawki  
 Vantuzlar  
 真空吸盘  
 真空カップ  
 진공 컵

Ventose modulari piGRIP® / piGRIP® modular suction cups / Modulare Saugnäpfe piGRIP® / Ventouses modulaires piGRIP® / Ventosas modulares piGRIP® / Ventosas modulares piGRIP® / Modulowe przyssawki piGRIP® / piGRIP® modüler vantuzlar / 模块化吸盘 / piGRIP® 組み合わせ型・吸着カップ / piGRIP® 모듈형 흡입 컵



TPE 60 Sh.A			Ø25 mm	VG.S25T60FS1	VG.S25T60B1S1	VG.S25T60B3S1	VG.S25T60B6S1
			Ø35 mm	VG.S35T60FS1	VG.S35T60B1S1	VG.S35T60B3S1	VG.S35T60B6S1
			Ø50 mm	VG.S50T60FS1	VG.S50T60B1S1	VG.S50T60B3S1	VG.S50T60B6S1
			Ø70 mm	VG.S70T60FS1	VG.S70T60B1S1	VG.S70T60B3S1	VG.S70T60B6S1
TPE 50 Sh.A			Ø25 mm	VG.S25T50FS1	VG.S25T50B1S1	VG.S25T50B3S1	VG.S25T50B6S1
			Ø35 mm	VG.S35T50FS1	VG.S35T50B1S1	VG.S35T50B3S1	VG.S35T50B6S1
			Ø50 mm	VG.S50T50FS1	VG.S50T50B1S1	VG.S50T50B3S1	VG.S50T50B6S1
			Ø70 mm	VG.S70T50FS1	VG.S70T50B1S1	VG.S70T50B3S1	VG.S70T50B6S1
TPE 50 Sh.A			Ø28 mm	VG.FX28T50FS1	VG.FX28T50B1S1	VG.FX28T50B3S1	VG.FX28T50B6S1
			Ø39 mm	VG.FX39T50FS1	VG.FX39T50B1S1	VG.FX39T50B3S1	VG.FX39T50B6S1
			Ø55 mm	VG.FX55T50FS1	VG.FX55T50B1S1	VG.FX55T50B3S1	VG.FX55T50B6S1
			Ø77 mm	VG.FX77T50FS1	VG.FX77T50B1S1	VG.FX77T50B3S1	VG.FX77T50B6S1
TPE 30 Sh.A			Ø28 mm	VG.FX28T30FS1	VG.FX28T30B1S1	VG.FX28T30B3S1	VG.FX28T30B6S1
			Ø39 mm	VG.FX39T30FS1	VG.FX39T30B1S1	VG.FX39T30B3S1	VG.FX39T30B6S1
			Ø55 mm	VG.FX55T30FS1	VG.FX55T30B1S1	VG.FX55T30B3S1	VG.FX55T30B6S1
			Ø77 mm	VG.FX77T30FS1	VG.FX77T30B1S1	VG.FX77T30B3S1	VG.FX77T30B6S1
Silicone 50 Sh.A			Ø34 mm	VG.BG34S50FS1	VG.BG34S50B1S1	VG.BG34S50B3S1	VG.BG34S50B6S1
			Ø48 mm	VG.BG48S50FS1	VG.BG48S50B1S1	VG.BG48S50B3S1	VG.BG48S50B6S1
			Ø63 mm	VG.BG63S50FS1	VG.BG63S50B1S1	VG.BG63S50B3S1	VG.BG63S50B6S1
NR			Ø25 mm	VG.FLI25FFS1	VG.FLI25FB1S1	VG.FLI25FB3S1	VG.FLI25FB6S1
			Ø35 mm	VG.FLI35FFS1	VG.FLI35FB1S1	VG.FLI35FB3S1	VG.FLI35FB6S1
			Ø50 mm	VG.FLI50FFS1	VG.FLI50FB1S1	VG.FLI50FB3S1	VG.FLI50FB6S1
			Ø70 mm	VG.FLI70FFS1	VG.FLI70FB1S1	VG.FLI70FB3S1	VG.FLI70FB6S1
EPDM			Ø25 mm	VG.FLI25SFS1	VG.FLI25SB1S1	VG.FLI25SB3S1	VG.FLI25SB6S1
			Ø35 mm	VG.FLI35SFS1	VG.FLI35SB1S1	VG.FLI35SB3S1	VG.FLI35SB6S1
			Ø50 mm	VG.FLI50SFS1	VG.FLI50SB1S1	VG.FLI50SB3S1	VG.FLI50SB6S1
			Ø70 mm	VG.FLI70SFS1	VG.FLI70SB1S1	VG.FLI70SB3S1	VG.FLI70SB6S1
HNBR 50 Sh.A			Ø29 mm	VG.HS29HN50FS1	VG.HS29HN50B1S1	VG.HS29HN50B3S1	VG.HS29HN50B6S1
			Ø39 mm	VG.HS39HN50FS1	VG.HS39HN50B1S1	VG.HS39HN50B3S1	VG.HS39HN50B6S1
			Ø58 mm	VG.HS58HN50FS1	VG.HS58HN50B1S1	VG.HS58HN50B3S1	VG.HS58HN50B6S1
			Ø79 mm	VG.HS79HN50FS1	VG.HS79HN50B1S1	VG.HS79HN50B3S1	VG.HS79HN50B6S1

Ventose  
 Vacuum cups  
 Saugnäpfe  
 Ventouses  
 Ventosas  
 Ventosas  
 Przyssawki  
 Vantuzlar  
 真空吸盘  
 真空カップ  
 진공 컵

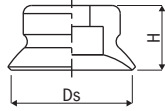

Ventose plane / Flat vacuum cups / Flachsaugnäpfe / Ventouses plates / Ventosa plana / Ventosas esféricas / Przyssawki płaskie / Düz Vantuzlar / 扁平真空吸盘 / 平型・真空カップ / 플랫폼 진공컵

VS.		Ds [mm]	H [mm]	m [g]
VS.PFG2NBR55N003	NBR	2	4	0.1
VS.PFG2SI55N003	SIL	2	4	0.1
VS.PFG3.5NBR55N003	NBR	3.5	4	0.3
VS.PFG3.5SI55N003	SIL	3.5	4	0.4
VS.PFG5HT160N004	HT1	5	6.5	0.2
VS.PFG5NBR55N004	NBR	5	6.5	0.2
VS.PFG5SI55N004	SIL	5	6.5	0.2
VS.PFG8HT160N004	HT1	8	7	0.2
VS.PFG8NBR55N004	NBR	8	7	0.2
VS.PFG8SI55N004	SIL	8	7	0.2
VS.PFG10HT160N004	HT1	10	7.5	0.2
VS.PFG10NBR55N004	NBR	10	7.5	0.31
VS.PFG10SI55N004	SIL	10	7.5	0.3
VS.PFG15HT160N005	HT1	15	8	0.7
VS.PFG15NBR55N005	NBR	15	8	0.7
VS.PFG15SI55N005	SIL	15	8	0.7
VS.PFG20HT160N006	HT1	20	10	1.4
VS.PFG20NBR55N006	NBR	20	10	1.5
VS.PFG20SI55N006	SIL	20	10	1.4
VS.PFG25HT160N007	HT1	25	14	2.4
VS.PFG25NBR55N007	NBR	25	14	2.2
VS.PFG25SI55N007	SIL	25	14	2.4
VS.PFG30HT160N007	HT1	28.8	12	3.5
VS.PFG30NBR55N007	NBR	28.8	12	3.3
VS.PFG30SI55N007	SIL	28.8	12	3.4
VS.PFG40HT160N007	HT1	40	14	7.6
VS.PFG40NBR55N007	NBR	40	14	7.6
VS.PFG40SI55N007	SIL	40	14	7.4
VS.PFG50HT160N008	HT1	50	15	10.6
VS.PFG50NBR55N008	NBR	50	15	10.2
VS.PFG50SI55N008	SIL	50	15	10.5
VS.PFG60HT160N009	HT1	60	18	24.2
VS.PFG60NBR55N009	NBR	60	18	24.7
VS.PFG60SI55N009	SIL	60	18	23.6
VS.PFG80HT160N009	HT1	80	18	51.2
VS.PFG80NBR55N009	NBR	80	18	52.8
VS.PFG80SI55N009	SIL	80	18	50.5
VS.PFG95NBR55N009	NBR	95	19	92.4
VS.PFG95SI55N009	SIL	95	19	87.9

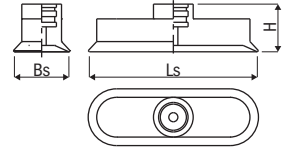

Ventose plane ovali / Flat oval vacuum cups / Ovale flache Saugnäpfe / Ventouses plates ovales / Ventosa plana ovalada / Ventosas planas ovals / Przyssawki płaskie owalne / Oval yassı vantuz / 扁平椭圆型真空吸盘 / 平型長円・真空カップ / 플랫폼 타원형 진공컵

VS.		Bs [mm]	Ls [mm]	H [mm]	m [g]
VS.SG04X2HT160N003	HT1	2	4	6	0.1
VS.SG04X2NBR60N003	NBR	2	4	6	0.1
VS.SG07X3.5HT160N003	HT1	3.5	7	6	0.1
VS.SG07X3.5NBR60N003	NBR	3.5	7	6	0.14
VS.SG015X5HT160N021	HT1	5	15	12	0.5
VS.SG015X5NBR60N021	NBR	5	15	12	0.5
VS.SG018X6HT160N021	HT1	6	18	12	0.5
VS.SG018X6NBR60N021	NBR	6	18	12	0.5
VS.SG024X8HT160N022	HT1	8	24	12	2.6
VS.SG024X8NBR60N022	NBR	8	24	12	2.6
VS.SG030X10HT160N022	HT1	10	30	12	2.8
VS.SG030X10NBR60N022	NBR	10	30	12	2.7
VS.SG045X15HT160N023	HT1	15	45	21	6.3
VS.SG045X15NBR60N023	NBR	15	45	21	6.3
VS.SG060X20HT160N023	HT1	20	60	21	9.7
VS.SG060X20NBR60N023	NBR	20	60	21	9.6
VS.SG075X25HT160N023	HT1	25	75	21	17.8
VS.SG075X25NBR60N023	NBR	25	75	21	17.8
VS.SG090X30NBR70N023	NBR	30	90	21	26

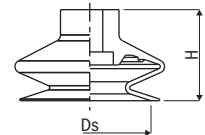

Ventose con 1.5 soffietti / Vacuum cups with 1.5 bellows / Saugnäpfe mit 1.5 Balgen / Ventouses avec 1.5 soufflets / Ventosas con 1.5 fuelles / Ventosas com 1.5 foles / Przyssawki z mieszkiem 1,5 / 1.5 körüklü vantuzlar / 1.5层真空吸盘 / 1.5 베로우스付き 真空カップ / 1.5 벨로우가 장착된 진공컵

VS.		Ds [mm]	H [mm]	m [g]
VS.FGA11HT160N016	HT1	10.4	16	0.9
VS.FGA11NBR55N016	NBR	10.4	16	0.9
VS.FGA11SI55N016	SIL	10.4	16	0.8
VS.FGA16HT160N016	HT1	15.6	19.2	1.2
VS.FGA16NBR55N016	NBR	15.6	19.2	1.3
VS.FGA16SI55N016	SIL	15.6	19.2	1.2
VS.FGA22HT160N016	HT1	21.5	19	1.9
VS.FGA22NBR55N016	NBR	21.5	19	1.9
VS.FGA22SI55N016	SIL	21.5	19	1.8
VS.FGA33HT160N018	HT1	30	27	7.3
VS.FGA33NBR55N018	NBR	30	27	7.3
VS.FGA33SI55N018	SIL	30	27	7
VS.FGA43HT160N018	HT1	38	27.6	11.5
VS.FGA43NBR55N018	NBR	38	27.6	11.6
VS.FGA43SI55N018	SIL	38	27.6	11
VS.FGA53HT160N018	HT1	50	34	19.4
VS.FGA53NBR55N018	NBR	50	34	19.3
VS.FGA53SI55N018	SIL	50	34	18.4
VS.FGA78HT160N019	HT1	74	47	60
VS.FGA78NBR55N019	NBR	74	47	58.4
VS.FGA78SI55N019	SIL	74	47	54.3

Ventose  
 Vacuum cups  
 Saugnäpfe  
 Ventouses  
 Ventosas  
 Ventosas  
 Przyssawki  
 Vantuzlar  
 真空吸盘  
 真空カップ  
 진공 컵

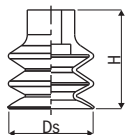

Ventose con 2.5 soffietti / Vacuum cups with 2.5 bellows / Saugnäpfe mit 2.5 Balgen / Ventouses avec 2.5 soufflets / Ventosas con 2.5 fuelles / Ventosas com 2.5 foles / Przyssawki z mieszkiem 2.5 / 2.5 körüklü vantuzlar / 2.5层真空吸盘 / 2.5 베로즈付き 真空キャップ / 2.5 벨로우가 장착된 진공컵

VS.		Ds [mm]	H [mm]	m [g]
VS.FG5HT160N017	HT1	5	14	0.3
VS.FG5NBR55N017	NBR	5	14	0.3
VS.FG5SI55N017	SIL	5	14	0.3
VS.FG9HT160N016	HT1	9	15	0.6
VS.FG9NBR55N016	NBR	9	15	0.6
VS.FG9SI55N016	SIL	9	15	0.6
VS.FG12HT160N016	HT1	12	21	1.1
VS.FG12NBR55N016	NBR	12	21	1.1
VS.FG12SI55N016	SIL	12	21	1.1
VS.FG14HT160N016	HT1	14.5	22.8	1.4
VS.FG14NBR55N016	NBR	14.5	22.8	1.4
VS.FG14SI55N016	SIL	14.5	22.8	1.3
VS.FG18HT160N016	HT1	17.2	22.6	1.9
VS.FG18NBR55N016	NBR	17.2	22.6	2.1
VS.FG18SI55N016	SIL	17.2	22.6	1.9
VS.FG20HT160N016	HT1	20	22.1	2
VS.FG20NBR55N016	NBR	20	22.1	2.2
VS.FG20SI55N016	SIL	20	22.1	2
VS.FG32HT160N018	HT1	32	37.5	9.5
VS.FG32NBR55N018	NBR	32	37.5	9.6
VS.FG32SI55N018	SIL	32	37.5	9
VS.FG42HT160N018	HT1	42.6	46	20.9
VS.FG42NBR55N018	NBR	42.6	46	22.5
VS.FG42SI55N018	SIL	42.6	46	20.6
VS.FG62HT160N018	HT1	62	54	40.3
VS.FG62NBR55N018	NBR	62	54	42.1
VS.FG62SI55N018	SIL	62	54	38.1
VS.FG88NBR55N019	NBR	89	86.5	166.6
VS.FG88SI55N019	SIL	89	86.5	155.6

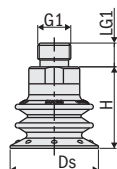

Ventose con 2.5 soffietti / Vacuum cups with 2.5 bellows / Saugnäpfe mit 2.5 Balgen / Ventouses avec 2.5 soufflets / Ventosas con 2.5 fuelles / Ventosas com 2.5 foles / Przyssawki z mieszkiem 2.5 / 2.5 körüklü vantuzlar / 2.5层真空吸盘 / 2.5 베로즈付き 真空キャップ / 2.5 벨로우가 장착된 진공컵

WD.	G1 [mm]	LG1 [mm]	H [mm]	Ds [mm]	m [g]
WD.0122869	M5	3.5	21.5	11	8
WD.0124344	M5	3.5	23.5	16	9
WD.0125108	1/8	7	21	21	9
WD.0114131	1/8	7	24	26	11
WD.9912151	1/8	6	33	37	19
WD.0106045	1/4	9	45	53	39



Nippli (per ventose serie VS.) / Nipples (for vacuum cups series VS.) / Nippel (für Saugnäpfe Serie VS.) / Mamelons (pour ventouses série VS.) / Racores (para ventosas de la serie VS.) / Acessórios (para ventosas série VS.) / Złąccki (do przyssawek serii VS.) / Nipel (VS. serisi vantuzlar için) / 螺母 (用于VS系列真空吸盘) / 真空カップVS用ニップル / 니플(VS 시리즈 진공컵용)

AVS.	M	m [g]
AVS.N003M3AG100	M3	0.18
AVS.N004M5AG200	M5	1.05
AVS.N004G18AG200	1/8	3.8
AVS.N005G18AG200	1/8	4.05
AVS.N006G18AG200	1/8	4.3
AVS.N007G18AG240	1/8	3.8
AVS.N008G18AG240	1/8	4.7
AVS.N009G14AG	1/4	9.3
AVS.N023G14AG350	1/4	9.6
AVS.N022G18AG350	1/8	3.8
AVS.N021M5AG200	M5	1.2
AVS.N016M5AG250	M5	1.02
AVS.N017M5AG200	M5	1.1
AVS.N018G14AG440	1/4	7.75
AVS.N019G14AG	1/4	14.2
AVS.N016G18AG350	1/8	4.13



Ventose  
Vacuum cups  
Saugnapfe  
Ventouses  
Ventosas  
Ventosas  
Przyssawki  
Vantuzlar  
真空吸盘  
真空カップ  
진공 컵



Ventose plane con nipplo / Flat vacuum cups with nipple / Flache Saugnapfe mit Nippel / Ventouses plates avec mamelon / Ventosa plana con racor / Ventosas planas com acessório / Przyssawki płaskie ze złączką / Yassı vantuzlar nipelieri ile birlikte / 帶螺母的扁平真空吸盘 / ニップル付・平型真空カップ / 니플이 달린 플랫폼 진공컵

WS.	(5)	(6)	m [g]
WS.PFYN2NBR55M3AG	VS.PFG2NBR55N003	AVS.N003M3AG100	0.28
WS.PFYN2SI55M3AG	VS.PFG2SI55N003	AVS.N003M3AG100	0.28
WS.PFYN3.5NBR55M3AG	VS.PFG3.5NBR55N003	AVS.N003M3AG100	0.48
WS.PFYN3.5SI55M3AG	VS.PFG3.5SI55N003	AVS.N003M3AG100	0.58
WS.PFYN5HT160M5AG	VS.PFG5HT160N004	AVS.N004M5AG200	1.25
WS.PFYN5NBR55M5AG	VS.PFG5NBR55N004	AVS.N004M5AG200	1.25
WS.PFYN5SI55M5AG	VS.PFG5SI55N004	AVS.N004M5AG200	1.25
WS.PFYN8HT160M5AG	VS.PFG8HT160N004	AVS.N004M5AG200	1.25
WS.PFYN8NBR55M5AG	VS.PFG8NBR55N004	AVS.N004M5AG200	1.25
WS.PFYN8SI55M5AG	VS.PFG8SI55N004	AVS.N004M5AG200	1.25
WS.PFYN10HT160G18AG	VS.PFG10HT160N004	AVS.N004G18AG200	4
WS.PFYN10HT160M5AG	VS.PFG10HT160N004	AVS.N004M5AG200	1.36
WS.PFYN10NBR55G18AG	VS.PFG10NBR55N004	AVS.N004G18AG200	4.1
WS.PFYN10NBR55M5AG	VS.PFG10NBR55N004	AVS.N004M5AG200	1.25
WS.PFYN10SI55G18AG	VS.PFG10SI55N004	AVS.N004G18AG200	4.11
WS.PFYN10SI55M5AG	VS.PFG10SI55N004	AVS.N004M5AG200	1.35
WS.PFYN15HT160G18AG	VS.PFG15HT160N005	AVS.N005G18AG200	4.75
WS.PFYN15NBR55G18AG	VS.PFG15NBR55N005	AVS.N005G18AG200	4.75
WS.PFYN15SI55G18AG	VS.PFG15SI55N005	AVS.N005G18AG200	4.75
WS.PFYN20HT160G18AG	VS.PFG20HT160N006	AVS.N006G18AG200	5.7
WS.PFYN20NBR55G18AG	VS.PFG20NBR55N006	AVS.N006G18AG200	5.8
WS.PFYN20SI55G18AG	VS.PFG20SI55N006	AVS.N006G18AG200	5.7
WS.PFYN25HT160G18AG	VS.PFG25HT160N007	AVS.N007G18AG240	6.2
WS.PFYN25NBR55G18AG	VS.PFG25NBR55N007	AVS.N007G18AG240	6
WS.PFYN25SI55G18AG	VS.PFG25SI55N007	AVS.N007G18AG240	6.2
WS.PFYN30HT160G18AG	VS.PFG30HT160N007	AVS.N007G18AG240	7.3
WS.PFYN30NBR55G18AG	VS.PFG30NBR55N007	AVS.N007G18AG240	7.1
WS.PFYN30SI55G18AG	VS.PFG30SI55N007	AVS.N007G18AG240	7.2
WS.PFYN40HT160G18AG	VS.PFG40HT160N007	AVS.N007G18AG240	11.4
WS.PFYN40NBR55G18AG	VS.PFG40NBR55N007	AVS.N007G18AG240	11.4
WS.PFYN40SI55G18AG	VS.PFG40SI55N007	AVS.N007G18AG240	11.2
WS.PFYN50HT160G18AG	VS.PFG50HT160N008	AVS.N008G18AG240	10.6
WS.PFYN50NBR55G18AG	VS.PFG50NBR55N008	AVS.N008G18AG240	10.2
WS.PFYN50SI55G18AG	VS.PFG50SI55N008	AVS.N008G18AG240	10.5
WS.PFYN60HT160G14AG	VS.PFG60HT160N009	AVS.N009G14AG	24.2
WS.PFYN60NBR55G14AG	VS.PFG60NBR55N009	AVS.N009G14AG	24.7
WS.PFYN60SI55G14AG	VS.PFG60SI55N009	AVS.N009G14AG	23.6
WS.PFYN80NBR55G14AG	VS.PFG80NBR55N009	AVS.N009G14AG	51.2
WS.PFYN80SI55G14AG	VS.PFG80SI55N009	AVS.N009G14AG	52.8
WS.PFYN80HT160G14AG	VS.PFG80HT160N009	AVS.N009G14AG	50.5
WS.PFYN95NBR55G14AG	VS.PFG95NBR55N009	AVS.N009G14AG	92.4
WS.PFYN95SI55G14AG	VS.PFG95SI55N009	AVS.N009G14AG	87.9

(5)  
Ventosa / Vacuum cup / Saugnapf / Ventouse / Ventosa / Ventosa / Przyssawka / Vantuz / 真空吸盘 / 真空カップ / 진공컵

(6)  
Nipplo / Nipple / Nippel / Mamelon / Niple / Acoplamento / Złączka / Nipel / 螺母 / ニップル / 니플



Ventose plane ovali con nipplo / Flat oval vacuum cups with nipple / Ovale flache Saugnapfe mit Nippel / Ventouses plates ovales avec mamelon / Ventosa plana ovalada con racor / Ventosas planas ovais com acessório / Przyssawki płaskie owalne ze złączką / Yassı oval vantuzlar nipelieri ile birlikte / 帶螺母的扁平橢圓形真空吸盘 / ニップル付・平型長門真空カップ / 니플이 달린 플랫폼 타원형 진공컵

WS.	(5)	(6)	m [g]
WS.SGON4X2HT1M3AG	VS.SG04X2HT160N003	AVS.N003M3AG100	0.28
WS.SGON4X2NBRM3AG	VS.SG04X2NBR60N003	AVS.N003M3AG100	0.28
WS.SGON7X3.5HT1M3AG	VS.SG07X3.5HT160N003	AVS.N003M3AG100	0.28
WS.SGON7X3.5NBRM3AG	VS.SG07X3.5NBR60N003	AVS.N003M3AG100	0.32
WS.SGON15X5HT1M5AG	VS.SG015X5HT160N021	AVS.N021M5AG200	0.71
WS.SGON15X5NBRM5AG	VS.SG015X5NBR60N021	AVS.N021M5AG200	0.71
WS.SGON18X6HT1M5AG	VS.SG018X6HT160N021	AVS.N021M5AG200	0.71
WS.SGON18X6NBRM5AG	VS.SG018X6NBR60N021	AVS.N021M5AG200	0.71
WS.SGON24X8HT1G18AG	VS.SG024X8HT160N022	AVS.N022G18AG350	6.4
WS.SGON24X8NBRG18AG	VS.SG024X8NBR60N022	AVS.N022G18AG350	6.4
WS.SGON30X10HT1G18AG	VS.SG030X10HT160N022	AVS.N022G18AG350	6.6
WS.SGON30X10NBRG18AG	VS.SG030X10NBR60N022	AVS.N022G18AG350	6.5
WS.SGON45X15HT1G18AG	VS.SG045X15HT160N023	AVS.N023G14AG350	15.9
WS.SGON45X15NBRG18AG	VS.SG045X15NBR60N023	AVS.N023G14AG350	15.9
WS.SGON60X20HT1G18AG	VS.SG060X20HT160N023	AVS.N023G14AG350	19.3
WS.SGON60X20NBRG18AG	VS.SG060X20NBR60N023	AVS.N023G14AG350	19.3
WS.SGON75X25NBRG14AG	VS.SG075X25NBR60N023	AVS.N023G14AG350	27.4
WS.SGON75X25HT1G14AG	VS.SG075X25HT160N023	AVS.N023G14AG350	27.4
WS.SGON90X30NBRG14AG	VS.SG090X30NBR70N023	AVS.N023G14AG350	35.6



Sistema di presa a depressione per "organo sheet" / Vacuum gripping system for "organo sheet" / Vakuüm-Greifsystem für "Organobleche" / Système de préhension à dépression pour "organo sheet" / Sistema de fijación por vacío para "órgano sheet" (láminas de fibra de carbono) / Sistema de apreensão por vácuo para "organo sheet" / System trzymania próżniowego dla „organo sheet” / “Organo sheet” için Vakumlu tutucu sistemi / 真空夾緊系統 / オルガノシート用・真空カップ / “organo sheet” 용 진공 시스템

PAAT	M [mm]	L [mm]	H [mm]	Ds [mm]	m [g]
PAAT16R	M5	5	21.5	Ø16	9
PAAT20R	M5	5	21.5	Ø20	9
PAAT30R	1/8	7.5	36	Ø30	35
PAAT40R	1/8	7.5	36	Ø40	37
PAAT50R	1/8	7.5	36	Ø50	41

Ventose  
 Vacuum cups  
 Saugnapfe  
 Ventouses  
 Ventosas  
 Ventosas  
 Przyssawki  
 Vantuzlar  
 真空吸盘  
 真空カップ  
 진공 컵

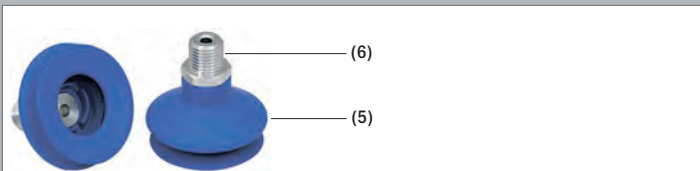

Ventose con 1.5 soffiatti con nipplo / Vacuum cups with 1.5 bellows with nipple / Saugnapfe mit 1.5 Balgen mit Nippel / Ventouses avec 1.5 soufflets avec mamelon / Ventosa de 1.5 fuelles con racor / Ventosas com 1.5 folas e acessório / Przyssawki z mieszkciem 1.5 ze złączką / 1.5 körüklü vantuzlar nipelleri ile birlikte / 1.5层带螺母的真空吸盘 / 1.5段·真空カップ / 니플이 달린 1.5 벨로우가 장착된 진공컵

WS.	(5)	(6)	m [g]
WS.FSGA11HT160G18AG	VS.FGA11HT160N016	AVS.N016G18AG350	5.03
WS.FSGA11HT160M5AG	VS.FGA11HT160N016	AVS.N016M5AG250	1.92
WS.FSGA11NBR55G18AG	VS.FGA11NBR55N016	AVS.N016G18AG350	5.03
WS.FSGA11NBR55M5AG	VS.FGA11NBR55N016	AVS.N016M5AG250	1.92
WS.FSGA11SI55G18AG	VS.FGA11SI55N016	AVS.N016G18AG350	5.03
WS.FSGA11SI55M5AG	VS.FGA11SI55N016	AVS.N016M5AG250	1.92
WS.FSGA16HT160G18AG	VS.FGA16HT160N016	AVS.N016G18AG350	5.33
WS.FSGA16HT160M5AG	VS.FGA16HT160N016	AVS.N016M5AG250	2.32
WS.FSGA16NBR55G18AG	VS.FGA16NBR55N016	AVS.N016G18AG350	5.33
WS.FSGA16NBR55M5AG	VS.FGA16NBR55N016	AVS.N016M5AG250	2.22
WS.FSGA16SI55G18AG	VS.FGA16SI55N016	AVS.N016G18AG350	5.43
WS.FSGA16SI55M5AG	VS.FGA16SI55N016	AVS.N016M5AG250	2.22
WS.FSGA22HT160G18AG	VS.FGA22HT160N016	AVS.N016G18AG350	6.03
WS.FSGA22HT160M5AG	VS.FGA22HT160N016	AVS.N016M5AG250	2.92
WS.FSGA22NBR55G18AG	VS.FGA22NBR55N016	AVS.N016G18AG350	5.93
WS.FSGA22NBR55M5AG	VS.FGA22NBR55N016	AVS.N016M5AG250	2.92
WS.FSGA22SI55G18AG	VS.FGA22SI55N016	AVS.N016G18AG350	6.02
WS.FSGA22SI55M5AG	VS.FGA22SI55N016	AVS.N016M5AG250	2.82
WS.FSGA33HT160G14AG	VS.FGA33HT160N018	AVS.N018G14AG440	15.05
WS.FSGA33NBR55G14AG	VS.FGA33NBR55N018	AVS.N018G14AG440	15.05
WS.FSGA33SI55G14AG	VS.FGA33SI55N018	AVS.N018G14AG440	14.75
WS.FSGA43HT160G14AG	VS.FGA43HT160N018	AVS.N018G14AG440	19.25
WS.FSGA43NBR55G14AG	VS.FGA43NBR55N018	AVS.N018G14AG440	19.35
WS.FSGA43SI55G14AG	VS.FGA43SI55N018	AVS.N018G14AG440	18.75
WS.FSGA53HT160G14AG	VS.FGA53HT160N018	AVS.N018G14AG440	27.15
WS.FSGA53NBR55G14AG	VS.FGA53NBR55N018	AVS.N018G14AG440	27.05
WS.FSGA53SI55G14AG	VS.FGA53SI55N018	AVS.N018G14AG440	26.15
WS.FSGA78NBR55G14AG	VS.FGA78NBR55N019	AVS.N019G14AG	74.20
WS.FSGA78SI55G14AG	VS.FGA78SI55N019	AVS.N019G14AG	72.6
WS.FSGA78HT160G14AG	VS.FGA78HT160N019	AVS.N019G14AG	68.5

(5)  
 Ventosa / Vacuum cup / Saugnapf / Ventouse / Ventosa / Ventosa / Przyssawka / Vantuz / 真空吸盘 / 真空カップ / 진공컵

(6)  
 Nipplo / Nipple / Nippel / Mamelon / Niple / Acoplamento / Złączka / Nipel / 螺母 / 니플 / 니플

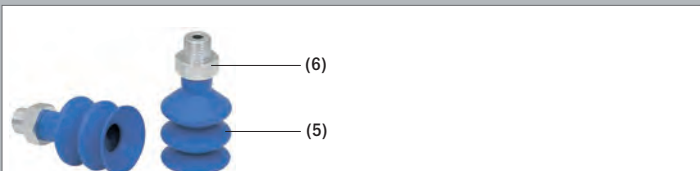

Ventose con 2.5 soffiatti con nipplo / Vacuum cups with 2.5 bellows with nipple / Saugnapfe mit 2.5 Balgen mit Nippel / Ventouses avec 2.5 soufflets avec mamelon / Ventosa de 2.5 fuelles con racor / Ventosas com 2.5 folas e acessório / Przyssawki z mieszkciem 2.5 ze złączką / 2.5 körüklü vantuzlar nipelleri ile birlikte / 2.5层带螺母的真空吸盘 / 2.5段·真空カップ / 니플이 달린 2.5 벨로우가 장착된 진공컵

WS.	(5)	(6)	m [g]
WS.FSG5HT160M5AG	VS.FG5HT160N017	AVS.N017M5AG200	1.4
WS.FSG5NBR55M5AG	VS.FG5NBR55N017	AVS.N017M5AG200	1.4
WS.FSG5SI55M5AG	VS.FG5SI55N017	AVS.N017M5AG200	1.4
WS.FSG9HT160G18AG	VS.FG9HT160N016	AVS.N016G18AG350	4.73
WS.FSG9HT160M5AG	VS.FG9HT160N016	AVS.N016M5AG250	1.62
WS.FSG9NBR55G18AG	VS.FG9NBR55N016	AVS.N016G18AG350	4.73
WS.FSG9NBR55M5AG	VS.FG9NBR55N016	AVS.N016M5AG250	1.62
WS.FSG9SI55G18AG	VS.FG9SI55N016	AVS.N016G18AG350	4.73
WS.FSG9SI55M5AG	VS.FG9SI55N016	AVS.N016M5AG250	1.62
WS.FSG12HT160G18AG	VS.FG12HT160N016	AVS.N016G18AG350	5.23
WS.FSG12HT160M5AG	VS.FG12HT160N016	AVS.N016M5AG250	2.12
WS.FSG12NBR55G18AG	VS.FG12NBR55N016	AVS.N016G18AG350	5.23
WS.FSG12NBR55M5AG	VS.FG12NBR55N016	AVS.N016M5AG250	2.12
WS.FSG12SI55G18AG	VS.FG12SI55N016	AVS.N016G18AG350	5.23
WS.FSG12SI55M5AG	VS.FG12SI55N016	AVS.N016M5AG250	2.12
WS.FSG14HT160G18AG	VS.FG14HT160N016	AVS.N016G18AG350	5.53
WS.FSG14HT160M5AG	VS.FG14HT160N016	AVS.N016M5AG250	2.42
WS.FSG14NBR55G18AG	VS.FG14NBR55N016	AVS.N016G18AG350	5.43
WS.FSG14NBR55M5AG	VS.FG14NBR55N016	AVS.N016M5AG250	2.42
WS.FSG14SI55G18AG	VS.FG14SI55N016	AVS.N016G18AG350	5.53
WS.FSG14SI55M5AG	VS.FG14SI55N016	AVS.N016M5AG250	2.32
WS.FSG18HT160G18AG	VS.FG18HT160N016	AVS.N016G18AG350	6.03
WS.FSG18HT160M5AG	VS.FG18HT160N016	AVS.N016M5AG250	3.12
WS.FSG18NBR55G18AG	VS.FG18NBR55N016	AVS.N016G18AG350	6.03
WS.FSG18NBR55M5AG	VS.FG18NBR55N016	AVS.N016M5AG250	2.92
WS.FSG18SI55G18AG	VS.FG18SI55N016	AVS.N016G18AG350	6.23
WS.FSG18SI55M5AG	VS.FG18SI55N016	AVS.N016M5AG250	2.92
WS.FSG20HT160G18AG	VS.FG20HT160N016	AVS.N016G18AG350	6.13
WS.FSG20HT160M5AG	VS.FG20HT160N016	AVS.N016M5AG250	3.22
WS.FSG20NBR55G18AG	VS.FG20NBR55N016	AVS.N016G18AG350	6.13
WS.FSG20NBR55M5AG	VS.FG20NBR55N016	AVS.N016M5AG250	3.02
WS.FSG20SI55G18AG	VS.FG20SI55N016	AVS.N016G18AG350	6.33
WS.FSG20SI55M5AG	VS.FG20SI55N016	AVS.N016M5AG250	3.02
WS.FSG32HT160G14AG	VS.FG32HT160N018	AVS.N018G14AG440	17.25
WS.FSG32NBR55G14AG	VS.FG32NBR55N018	AVS.N018G14AG440	17.25
WS.FSG32SI55G14AG	VS.FG32SI55N018	AVS.N018G14AG440	17.25
WS.FSG42HT160G14AG	VS.FG42HT160N018	AVS.N018G14AG440	28.65
WS.FSG42NBR55G14AG	VS.FG42NBR55N018	AVS.N018G14AG440	30.25
WS.FSG42SI55G14AG	VS.FG42SI55N018	AVS.N018G14AG440	28.35
WS.FSG62HT160G14AG	VS.FG62HT160N018	AVS.N018G14AG440	48.05
WS.FSG62NBR55G14AG	VS.FG62NBR55N018	AVS.N018G14AG440	49.85
WS.FSG62SI55G14AG	VS.FG62SI55N018	AVS.N018G14AG440	45.85
WS.FSG88NBR55G14AG	VS.FG88NBR55N019	AVS.N019G14AG	180.8
WS.FSG88SI55G14AG	VS.FG88SI55N019	AVS.N019G14AG	169.8

Ventose  
Vacuum cups  
Saugnapfe  
Ventouses  
Ventosas  
Ventosas  
Przyssawki  
Vantuzlar  
真空吸盘  
真空カップ  
진공 컵

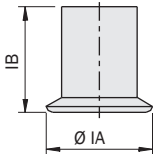

Ventose plane / Flat vacuum cups / Flachsaußnapfe / Ventouses plates / Ventosa plana / Ventosas esféricas / Przyssawki płaskie / Düz vantuz / 扁平真空吸盘 / 平型・真空カップ / 플랫폼 진공컵

VP.		IA [mm]	IB [mm]
VP.3150114	CR	Ø5	6.1
VP.3150114S	SIL	Ø5	6.1
VP.3150115	CR	Ø7	7
VP.3150115S	SIL	Ø7	7
VP.3150116	CR	Ø9	7
VP.3150116S	SIL	Ø9	7
VP.3150117	CR	Ø11	10.5
VP.3150117S	SIL	Ø11	10.5

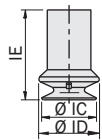

Ventose a soffietto / Bellow vacuum cups / Balgsaußnapfe / Ventouses à soufflet / Ventosa con fuelle / Ventosas com fole / Przyssawki z mieszkciem / Körüklü vantuz / 多层真空吸盘 / 베로어型・真空カップ / 벨로우 진공컵

VP.		IC [mm]	ID [mm]	IE [mm]
VP.3150286	CR	Ø5.6	Ø6.2	9.2
VP.3150286S	SIL	Ø5.6	Ø6.2	9.2
VP.3150287	CR	Ø8.8	Ø9.6	11.9
VP.3150287S	SIL	Ø8.8	Ø9.6	11.9
VP.3150101	CR	Ø11	Ø12	16.4
VP.3150101S	SIL	Ø11	Ø12	16.4

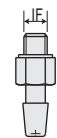

Nippli / Nipples / Nippel / Mamelons / Niples / Acessórios de ventosa / Złączki / Nipeller / 螺母 / 니플러 / 니플

AVP.		IF	m [g]
AVP.3107031		M5	3
AVP.3107030		M5	4



Pressore a molla / Spring rod / Federhalterung / Pressoir a ressort / Muelle vástago / Amortecedor por mola / Pręta elastyczny / Yaylı itici / 弹簧杆 / 스프링로드 / 스프링로드 핀

V SX		m [g]
V SX1425		65



Nippli / Nipples / Nippel / Mamelons / Niples / Acessórios de ventosa / Złączki / Nipeller / 螺母 / 니플러 / 니플

AF		GR	m [g]
AF05M05M		M5	3
AF18M18M		G1/8"	4
AF14M14M		G1/4"	8
AF12F16M			25
AF17F25M			130
AF27F33M			140
AF10G18M	NEW		18



Dado / Nut / Mutter / Écrou / Tuerca / Porcar / Nakrętko / Somunlar / 螺母 / 六角ナット / 너트

VITE-293			m [g]
VITE-293		M12x1	4
VITE-455		M17x1	7
VITE-456		M27x1	23



Giunti angolari / Elbow arms / Gelenkverbindungen / Joints angulaires / Juntas angulares / Juntas angulares / Ramiona kątowe / Açı verme aparatı / 弯臂 / 真空カップ固定用・エルボアーム / 엘보우 암

VA		IG	IH	m [g]
VAM5M5G		M5	M5	28
VAM18M18G		G1/8"	G1/8"	64
VAM18M14G		G1/4"	G1/8"	70
VAM14M14G		G1/4"	G1/4"	76



Giunti angolari / Elbow arms / Gelenkverbindungen / Joints angulaires / Juntas angulares / Juntas angulares / Ramiona kątowe / Açı verme aparatı / 弯臂 / 真空カップ固定用・エルボアーム / 엘보우 암

VAC		IL	IM	m [g]
VAC05F05F		M5	M5	10
VAC18F18F		G1/8"	G1/8"	15
VAC14F14F		G1/4"	G1/4"	40

Sospensioni  
 Suspensions  
 Aufhängungen  
 Suspensions  
 Suspensión  
 Suspensão  
 Uchwyty do zawieszania  
 Süspansiyonlar  
 悬件  
 サスペンション  
 서스펜션



Sospensioni universali anti-rotazione / Non-rotative universal suspensions / Drehgesicherte Universal-Aufhängungen / Suspensions universelles anti-rotation / Suspensión universal anti-rotación / Suspensão universal antirotação / Zawieszenia uniwersalne zabezpieczone przed obrotem / Genel amaçlı dönmez süspansiyonlar / 非可旋转通用悬件 / 回り止め付・汎用サスペンション / 비회전식 범용 서스펜션

VMK	F [N]	s [mm]	m [g]
VMK14	5÷6	10	55
VMK20	7÷10	13	160
VMK30	7÷10	16	250



Sospensioni telescopiche anti-rotazione, con corpo liscio / Telescopic non-rotative vacuum suspensions, with smooth body / Drehgesicherte Teleskopaufhängungen, mit glatter Gehäuse / Suspensions télescopiques anti-rotation, avec corps lisse / Compensador de nivel telescópico anti-rotación, con el cuerpo liso / Suspensão telescópica anti- rotação com corpo liso / Teleskopowe zawieszenia nierotacyjne z korpusem o gładkiej powierzchni / Teleskobik dönmez vakum süspansiyonları, düz gövde / 平滑主体的非可旋转伸缩悬件 / 回り止め付・多段サスペンション (丸棒型) / 접었다 펼 수 있는 비회전식 진공 서스펜션, 스무스 바디

VSL	IO	IN	s [mm]	m [g]
VSL1620	Ø16	M5	20	30
VSL2030	Ø20	G1/8"	30	55
VSL2430	Ø24	G1/4"	30	70



Sospensioni telescopiche anti-rotazione, con corpo filettato / Telescopic non-rotative vacuum suspensions, with threaded body / Drehgesicherte Teleskopaufhängungen, mit Gewindegehäuse / Suspensions télescopiques anti-rotation, avec corps taraudé / Compensador de nivel telescópico anti-rotación, con el cuerpo roscado / Suspensão telescópica anti- rotação com corpo roscado / Teleskopowe zawieszenia nierotacyjne z gwintowanym korpusem / Teleskobik dönmez vakum süspansiyonları, dişli gövde / 螺纹主体的非可旋转伸缩悬件 / 回り止め付・多段サスペンション (おねじ型) / 접었다 펼 수 있는 비회전식 진공 서스펜션, 나사산이 있는 바디

VSC	IP	IQ	s [mm]	m [g]
VSC1620	M16x1	M5	20	35
VSC2230	M22x1.5	G1/8"	30	80
VSC2530	M25x1.5	G1/4"	30	115



Sospensioni telescopiche auto-ritraenti / Telescopic self-retracting suspensions / Selbst-einziehbare Teleskop-Aufhängungen / Suspensions télescopiques auto rétractables / Compensador telescópico retráctil / Compensador de nivel auto-retráctil / Teleskopowe zawieszenia samocofojące się / Teleskobik kendiliğinden geri çekilen süspansiyonlar / 伸缩悬件 / 回り止め無・真空用サスペンション (単動) / 접었다 펼 수 있는 셀프 리트랙팅 서스펜션

VSS	IR	IS	s [mm]	m [g]
VSS2025	M5	G1/8"	25	40
VSS2050	M5	G1/8"	50	50



Sospensioni rotanti, con corpo liscio / Rotative vacuum suspensions, with smooth body / Drehbare Aufhängungen, mit glatter Gehäuse / Suspensions sans anti-rotation, avec corps lisse / Compensador de nivel con rotación, con el cuerpo liso / Suspensão rotativa com corpo liso / Zawieszenia rotacyjne z korpusem o gładkiej powierzchni / Dönebilen vakum süspansiyonları, düz gövde / 平滑主体的可旋转悬件 / 回り止め無・真空用サスペンション (丸棒型) / 회전식 진공 서스펜션, 스무스 바디

VSR	IV	IT	s [mm]	m [g]
VSR1010	M5	Ø10	10	7
VSR1025	M5	Ø10	25	11
VSR1420	G1/8"	Ø14	20	23
VSR1435	G1/8"	Ø14	35	32
VSR2025	G1/8"	Ø20	25	50
VSR2050	G1/8"	Ø20	50	77



Sospensioni rotanti, con corpo filettato / Rotative vacuum suspensions, with threaded body / Drehbare Aufhängungen, mit Gewindegehäuse / Suspensions sans anti-rotation, avec corps taraudé / Compensador de nivel con rotación, con el cuerpo roscado / Suspensão rotativa com corpo roscado / Zawieszenia rotacyjne z gwintowanym korpusem / Dönebilen vakum süspansiyonları, dişli gövde / 螺纹主体的可旋转悬件 / 回り止め無・真空用サスペンション (おねじ型) / 회전식 진공 서스펜션, 나사산이 있는 바디

VSRT	LB	LA	s [mm]	m [g]
VSRT1010	M5	M10x1	10	11
VSRT1025	M5	M10x1	25	16
VSRT1420	G1/8"	M14x1.5	20	32
VSRT1435	G1/8"	M14x1.5	35	42
VSRT1620	G1/8"	M16x1	20	40
VSRT1635	G1/8"	M16x1	35	50
VSRT2025	G1/8"	M20x1.5	25	70
VSRT2050	G1/8"	M20x1.5	50	104

Sospensioni  
Suspensions  
Aufhängungen  
Suspensions  
Suspensión  
Suspensão  
Uchwyty do zawieszania  
Süspansiyonlar  
悬件  
サスペンション  
서스펜션



Sospensioni anti-rotazione, con corpo liscio / Non-rotative vacuum suspensions, with smooth body / Drehgesicherte Aufhängungen, mit glattem Gehäuse / Suspensions anti-rotation, avec corps lisse / Compensador de nivel anti-rotación, con el cuerpo liso / Suspensão anti-rotação com corpo liso / Zawieszenia nierotacyjne z korpusem o gładkiej powierzchni / Dönmez süspansiyonlar, düz gövde / 平滑主体的非可旋转伸缩悬件 / 回り止め付・真空用サスペンション(丸棒型) / 비회전식 진공 서스펜션, 스무스 바디

VSN	LD	LC [mm]	s [mm]	m [g]
VSN1010	M5	Ø10	10	7
VSN1025	M5	Ø10	25	11
VSN1420	G1/8"	Ø14	20	24
VSN1435	G1/8"	Ø14	35	33
VSN2025	G1/8"	Ø20	25	54
VSN2050	G1/8"	Ø20	50	80



Sospensioni anti-rotazione, con corpo filettato / Non-rotative vacuum suspensions, with threaded body / Drehgesicherte Aufhängungen, mit Gewindegehäuse / Suspensions anti-rotation, avec corps taraudé / Compensador de nivel anti-rotación, con el cuerpo roscado / Suspensão anti-rotação com corpo roscado / Zawieszenia nierotacyjne z gwintowanym korpusem / Dönmez süspansiyonlar, dişli gövde / 螺纹主体的非可旋转伸缩悬件 / 回り止め付・真空用サスペンション(おねじ型) / 비회전식 진공 서스펜션, 나사산이 있는 바디

VSN	LF	LE	s [mm]	m [g]
VSN1010	M5	M10x1	10	12
VSN1025	M5	M10x1	25	16



Sospensioni anti-rotazione con giunto angolare integrato, con corpo liscio / Non-rotative suspensions with integrated elbow arms, with smooth body / Drehgesicherte Aufhängungen mit integriertem Winkelgelenk, mit glattem Gehäuse / Suspensions anti-rotation avec joint angulaire intégré, avec corps lisse / Compensador de nivel anti-rotación, con brazo giratorio integrado y cuerpo liso / Suspensão anti-rotação com junta angular integrada e corpo liso / Zawieszenia nierotacyjne z korpusem o gładkiej powierzchni, ze zintegrowanym przegubem / Açılı ayarlı dönmez süspansiyonlar, düz gövde / 平滑主体的带集成的非可旋转悬件 / 回り止め付・エルボアーム組込み型サスペンション(丸棒型) / 통합 엘보우 암이 장착된 비회전식 서스펜션, 스무스 바디

VSE	LG [mm]	LH	s [mm]	m [g]
VSE1010F05	NEW Ø10	M5	10	15
VSE1025F05	NEW Ø10	M5	25	20
VSE1420F18	NEW Ø14	G1/8"	20	45
VSE1435F18	NEW Ø14	G1/8"	35	55
VSE2025F18	NEW Ø20	G1/8"	25	70
VSE2025F14	NEW Ø20	G1/4"	25	90
VSE2050F18	NEW Ø20	G1/8"	50	105
VSE2050F14	NEW Ø20	G1/4"	50	120



Sospensioni anti-rotazione con giunto angolare integrato, con corpo filettato / Non-rotative suspensions with integrated elbow arms, with threaded body / Drehgesicherte Aufhängungen mit integriertem Winkelgelenk, mit Gewindegehäuse / Suspensions anti-rotation avec joint angulaire intégré, avec corps taraudé / Compensador de nivel anti-rotación, con brazo giratorio integrado y cuerpo roscado / Suspensão anti-rotação com junta angular integrada e corpo roscado / Zawieszenia nierotacyjne z gwintowanym korpusem, ze zintegrowanym przegubem / Açılı ayarlı dönmez süspansiyonlar, dişli gövde / 螺纹主体的带集成弯臂的非可旋转悬件 / 回り止め付・エルボアーム組込み型サスペンション(おねじ型) / 통합 엘보우 암이 장착된 비회전식 서스펜션, 나사산이 있는 바디

VSET	LI	LM	s [mm]	m [g]
VSET1010F05	NEW M10x1	M5	10	18
VSET1025F05	NEW M10x1	M5	25	23
VSET1620F18	NEW M16x1	G1/8"	20	57
VSET1635F18	NEW M16x1	G1/8"	35	70
VSET2025F18	NEW M20x1.5	G1/8"	25	88
VSET2025F14	NEW M20x1.5	G1/4"	25	109
VSET2050F18	NEW M20x1.5	G1/8"	50	125
VSET2050F14	NEW M20x1.5	G1/4"	50	142



Sospensioni inox anti-rotazione per carichi elevati / Non-rotative heavy duty stainless suspensions / Drehgesicherte Aufhängungen aus rostfreiem Stahl für hohe Lasten / Suspensions inox anti-rotation pour charges élevées / Suspensões de aço inoxidável antirrotación para cargas elevadas / Suspensões em inox anti-rotação para trabalhos pesados / Zawieszenia nierotacyjne ze stali nierdzewnej wzmacnione / Ağır şartlar için dönmez, çelik süspansiyonlar / 非可旋转重型不锈钢悬件 / 回り止め付・ヘビーデューティー・ステンレス製サスペンション / 비회전식 고강도 스테인리스 서스펜션

VVX	LN [mm]	LO	s [mm]	m [g]
VVX1010F	Ø10	M5	10	30
VVX1025F	Ø10	M5	25	45
VVX1420F	Ø14	G1/8"	20	80
VVX1435F	Ø14	G1/8"	35	110
VVX2025F	Ø20	G1/8"	25	150
VVX2050F	Ø20	G1/8"	50	235



Sospensioni inox rotanti con corpo filettato / Rotative stainless suspensions with threaded body / Drehbare Aufhängungen aus rostfreiem Stahl mit Gewindegehäuse / Suspensions inox rotatives avec corps fileté / Compensadores de nivel con rotación, en acero inox, y cuerpo roscado / Suspensões em inox rotativa com corpo roscado / Zawieszenia nierotacyjne ze stali nierdzewnej z gwintowanym korpusem / Dişli gövdeli, dönebilen, paslanmaz süspansiyonlar / 螺纹主体的非可旋转悬件 / 回り止め無・ステンレス製サスペンション(おねじ型) / 나사산이 있는 바디가 포함된 회전식 스테인리스 서스펜션

VSRG	LP	LQ	s [mm]	m [g]
VSRG1225	M5	M12x1	25	50
VSRG1635	G1/8"	M16x1	35	110
VSRG2050	G1/4"	M20X1.5	50	220
VSRG2580	G3/8"	M25x1.5	80	560

Sospensioni  
 Suspensions  
 Aufhängungen  
 Suspensions  
 Suspensión  
 Suspensão  
 Uchwyty do zawieszania  
 Süspansiyonlar  
 悬件  
 サスペンション  
 서스펜션



Sospensioni anti-rotazione con corpo liscio / Smooth-body non rotative telescopic suspensions / Drehgesicherte Aufhängungen mit glattem Körper / Suspensions anti-rotation avec corps lisse / Compensador de nivel anti-rotación, con el cuerpo liso / Suspensão anti-rotação com corpo liso / Zawieszenia nierotacyjne z korpusem o gładkiej powierzchni / Düz gövdeli dönmez teleskobik süspansiyonlar / 平滑主体的非可旋转伸缩悬件 / 回り止め付・多段サスペンション(丸棒型) / 스무스바디로 접었다 펼 수 있는 비회전식 서스펜션

VSNG		LR	LS [mm]	s [mm]	m [g]
VSNG1010	NEW	M5	Ø10	10	7
VSNG1025	NEW	M5	Ø10	25	11
VSNG1210		M5	Ø12	10	15
VSNG1225		M5	Ø12	25	20
VSNG1420	NEW	G1/8"	Ø14	20	22
VSNG1435	NEW	G1/8"	Ø14	35	33
VSNG1620		G1/8"	Ø16	20	40
VSNG1635		G1/8"	Ø16	35	50
VSNG2025F18	NEW	G1/8"	Ø20	25	54
VSNG2025		G1/4"	Ø20	25	55
VSNG2050F18	NEW	G1/8"	Ø20	50	80
VSNG2050		G1/4"	Ø20	50	85
VSNG2540		G3/8"	Ø25	40	135
VSNG2580		G3/8"	Ø25	80	205



Sospensioni anti-rotazione con corpo filettato / Threaded-body non rotative telescopic suspensions / Drehgesicherte Aufhängungen mit Gewinde / Suspensions anti-rotation avec corps fileté / Compensador de nivel anti-rotación, con el cuerpo roscado / Suspensão anti-rotação com corpo roscado / Zawieszenia nierotacyjne z gwintowanym korpusem / Dişli gövdeli dönmez süspansiyonlar / 螺纹主体的非可旋转悬件 / 回り止め付・多段サスペンション(おねじ型) / 나사산이 있는 바디로 접었다 펼 수 있는 비회전식 서스펜션

VSNTG		LT	LV [mm]	s [mm]	m [g]
VSNTG1010	NEW	M5	M10x1	10	7
VSNTG1025	NEW	M5	M10x1	25	11
VSNTG1210		M5	M12x1	10	15
VSNTG1225		M5	M12x1	25	20
VSNTG1420	NEW	G1/8"	M14x1.5	20	22
VSNTG1435	NEW	G1/8"	M14x1.5	35	33
VSNTG1620		G1/8"	M16x1	20	35
VSNTG1635		G1/8"	M16x1	35	45
VSNTG2025F18	NEW	G1/8"	M20x1.5	25	54
VSNTG2025		G1/4"	M20x1.5	25	65
VSNTG2050F18	NEW	G1/8"	M20x1.5	50	80
VSNTG2050		G1/4"	M20x1.5	50	90
VSNTG2540		G3/8"	M25x1.5	40	170
VSNTG2580		G3/8"	M25x1.5	80	235



Sospensioni anti-rotazione con cravatta regolabile e corpo liscio / Non-rotative suspensions with smooth-body and adjustable clamp / Drehgesicherte Aufhängungen mit einstellbarer Klemme und glattem Gehäuse / Suspension anti-rotation avec support réglable et corps lisse / Suspensión anti-rotación con soporte regulable y cuerpo liso / Suspensão anti-rotação com suporte regulável e corpo liso / Zawieszenia nierotacyjne z korpusem o gładkiej powierzchni i regulowanym zaciskiem / Dönmez süspansiyonlar düz gövdeli, ayarlanabilir kelepçeli / 平滑主体的带可调节钳夹的非可旋转悬件 / 回り止め付・サスペンション(丸棒型、角度調整型クランプ付) / 스푸스 바디로 조절 가능한 클램프가 장착된 비회전식 서스펜션

VSD		MA [mm]	MB [mm]	s [mm]	m [g]
VSD1420D10	NEW	Ø14	Ø10	20	43
VSD2025D10	NEW	Ø20	Ø10	25	69
VSD2025D20	NEW	Ø20	Ø20	25	85

Tubi flessibili  
Hoses  
Schläuche  
Tubes flexibles  
Tubos flexibles  
Tubos flexíveis  
Węże  
Hortumlar  
软管  
エアチューブ  
호스

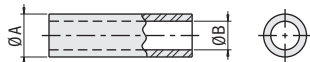

TU		ØA [mm]	ØB [mm]	m [g/m]
TUB04X2,5B	Black	4	2.5	9.49
TUB04X2,5BL	Blue	4	2.5	9.49
TUB04X2,5GR	Green	4	2.5	9.49
TUB04X2,5RE	Red	4	2.5	9.49
TUB04X2,5SI	Silver	4	2.5	9.49
TUB04X2,5YE	Yellow	4	2.5	9.49
TUB06X4B	Black	6	4	19.47
TUB06X4BL	Blue	6	4	19.47
TUB06X4GR	Green	6	4	19.47
TUB06X4RE	Red	6	4	19.47
TUB06X4SI	Silver	6	4	19.47
TUB06X4YE	Yellow	6	4	19.47
TUB08X6B	Black	8	6	30
TUB08X6BL	Blue	8	6	30
TUB08X6SI	Silver	8	6	30
TUB08X6YE	Yellow	8	6	30

Attuatore a depressione  
Vacuum actuator  
Unterdruckantrieb  
Vérin à dépression  
Actuador de depresión  
Actuador de pressão  
Siłownik pneumatyczny  
Vakum aktuatörleri  
真空执行器  
真空圧駆動アクチュエータ  
진공 액츄에이터



VAQ	F [N]	s [mm]	m [g]
VAQ1820	10	20	90
VAQ1840	10	40	125
VAQN1820	10	20	105
VAQN1840	10	40	145

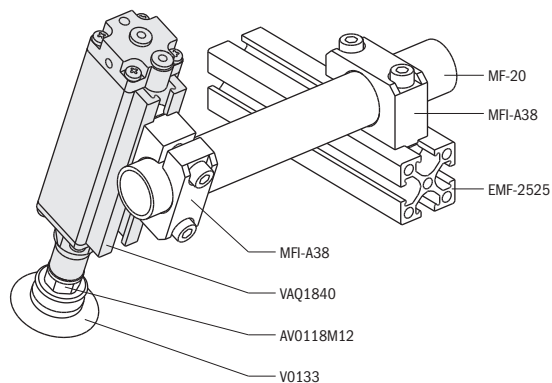

Pompe a vuoto  
 Vacuum pumps  
 Vakuumpumpen  
 Pompes à vide  
 Bombas de vacío  
 Bombas de vácuo  
 Pompy próżniowe  
 Vakum Üreteçleri  
 真空泵  
 真空エジェクター  
 진공 펌프

Raccordi  
 Fittings  
 Fittings Raccords  
 Raccords  
 Racordaje  
 Racord  
 Złącza  
 Rakorlar  
 接头  
 fittings  
 피팅



PV.	m
	[g]
PV.0122882	9.8
PV.0122025	23
PV.0122896	21.8



Raccordo diritto a calzamento / Straight push-on fitting / Gerade Verschraubung zum Aufstecken / Raccord droit à emboîtement / Racor rápido directo / Racord direito por embutimento / Złączka prosta wciskana / Düz rakor / 直推式接头 / タケノコ継手 (ストレート) / 스트레이트 푸시온 피팅

RG.	MD	MC	
		[mm]	
RG.R0-1376-AS1	M3	Ø4	(1)

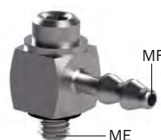

Raccordo orientabile a "L" a calzamento / Adjustable-position push-on elbow fitting / Schwenkbare L-förmige Verschraubung zum Aufstecken / Raccord orientable en L à emboîtement / Racor rápido en codo orientable / Racord orientável em "L" por embutimento / Złączka katowa wciskana regulowana / Dirsek rakor / 可调节位置的推入式弯臂接头 / タケノコ継手 (エルボ、回転型) / 위치 조절 가능한 푸시온 엘보우 피팅

RG.	ME	MF	
		[mm]	
RG.R0-1376-AS2	M3	Ø4	(1)



Raccordo diritto maschio cilindrico / Straight male adaptor (parallel) / Gerade Einschraubverschraubung zylindrisch / Raccord droit mâle, cylindrique / Racor directo macho cilíndrico / Racord direito macho cilíndrico / Proste złącze męskie / Otomatik düz rakor / 直螺纹接头 (平行) / ワンタッチ継手 (コネクター、平行ねじ) / 스트레이트 수 어댑터(평행)

RG.	MG	MH	
		[mm]	
RG.50-020-00N01	M5	4	(1)
RG.5002000N02	1/8	4	(1)
RG.5002000N22	1/4	4	(1)
RG.5002000N20	M5	6	(1)
RG.5002000N03	1/8	6	(1)
RG.5002000N04	1/4	6	(1)
RG.5002000N05	1/8	8	(1)
RG.5002000N06	1/4	8	(1)

(1)  
 Confezione da 10 pezzi / 10 pieces package / 10 Stück Packung / Vendu par 10 pièces / Paquete de 10 piezas / Embalagem de 10 peças / 10 sztuk w opakowaniu / Her paket 10 Adettir / 10个一包 / 一袋10個入 / 10피스 패키지



**Raccordi**  
**Fittings**  
**Fittings Raccords**  
**Raccords**  
**Racordaje**  
**Racord**  
**Złącza**  
**Rakorlar**  
**接头**  
**フィッティング**  
**피팅**



Raccordo a L orientabile maschio cilindrico / Orienting elbow male adaptor (parallel) / Winkelverschraubung zylindrisch (drehbar) / Équerre orientable mâle, cylindrique / Racor en L orientable macho cilíndrico / Racord em "L" orientável macho cilíndrico / Kolano cylindryczne męskie z regulacją pozycji / Otomatik dirsek rakor / 定向弯臂螺纹接头 (平行) / ワンタッチ継手 (エルボ、回転型、平行ねじ) / 방향성 엘보우 수 어댑터 (평행)

RG.	MI	ML [mm]	
RG.5511600001	M3x0.5	4	(1)
RG.5511600002	M5	4	(1)
RG.5511600004	1/8	4	(1)
RG.5511600011	M5	6	(1)
RG.5511600013	1/8	6	(1)
RG.5511600014	1/4	6	(1)
RG.5511600017	1/8	8	(1)
RG.5511600018	1/4	8	(1)



Raccordo a T orientabile maschio cilindrico / Orienting Tee male adaptor (parallel) - centre leg / T-Einschraubverschraubung zylindrisch (drehbar) / Té orientable à piquage mâle central, cylindrique / Racor en T orientable macho cilíndrico / Racord em "T" orientável macho cilíndrico / Trójnik cylindryczny męski z regulacją pozycji / Otomatik T rakor / 定向T型螺纹接头 / ワンタッチ継手 (ティー、回転型、平行ねじ) / 방향성 티 수 어댑터 (평행) - 센터렉

RG.	MM	MN [mm]	
RG.5521600002	M5	Ø4	(1)
RG.5521600011	M5	Ø6	(1)
RG.5521600013	1/8	Ø6	(1)
RG.5521600014	1/4	Ø6	(1)
RG.5521600017	1/8	Ø8	(1)
RG.5521600018	1/4	Ø8	(1)



Raccordo diritto intermedio / Straight connector / Verbindungsverschraubung / Racord union double / Racor directo unión doble / Racord direito intermédio / Złącza prosta / Hortum birleştrici / 直管接头 / ワンタッチ継手 (ストレート、中間用) / 스트레이트 커넥터

RG.	MP [mm]	
RG.5504000002	Ø4	(1)
RG.5504000004	Ø6	(1)
RG.5504000009	Ø6	(1)
RG.5504000005	Ø8	(1)
RG.5504000010	Ø8	(1)



Raccordo a T intermedio / Tee connector / T-Anschluss / Raccord té / Racor en T / Racord em "T" intermédio / Złącza trójnik / T bağlantı / T型接头 / ワンタッチ継手 (ティー、中間用) / 티 커넥터

RG.	MQ [mm]	
RG.5523000002	Ø4	(1)
RG.5523000004	Ø6	(1)
RG.5523000005	Ø8	(1)



Raccordo a Y intermedio / Y connector / Y-Anschluss / Raccord en y simple / Racor en Y / Racord em "Y" intermédio / Złącza rozgałęźnik / Y bağlantı / Y型接头 / ワンタッチ継手 (Y型、中間用) / Y 커넥터

RG.	MR [mm]	
RG.5531000002	Ø4	(1)
RG.5531000004	Ø6	(1)
RG.5531000005	Ø8	(1)



Raccordo multiplo di riduzione / Reduction manifold / T-Mehrfachverteiler reduziert / Multi-té réduit / Racordaje / Racord / Rozgałęźnik redukcyjny / Çoklu redüksiyon / 简单的分流管 / ワンタッチ継手 (変径、分岐用) / 축소 매니폴드

RG.	MS [mm]	
RG.5535000001	6-4	(1)
RG.5535000002	8-4	(1)
RG.5535000003	8-6	(1)



Tappo in poliamide / Plug polyamede / Verschlusszapfen Polyamid / Bouchon en polyamide / Tapón de poliamida / Tampão em poliamida / Wtyczka z poliamidu / Körtapa / 聚酰胺塞子 / ブロックプラグ / 폴리아미드 플러그

RG.	MT [mm]	
RG.086100031X1R0	Ø4	(1)
RG.086100031X4R0	Ø6	(1)
RG.086100031X7R0	Ø8	(1)

Raccordi  
Fittings  
Fittings Raccords  
Raccords  
Racordaje  
Racord  
Złącza  
Rakorlar  
接头  
フィットिंग  
피팅



Regolatore di flusso unidirezionale orientabile (regolazione a cacciavite) / Swivel unidirectional flow controller (adjustment by screwdriver) / Beweglicher Einweg-Durchflussregler (einstellbar mit Schraubenzieher) / Régulateur de débit unidirectionnel orientable (réglage par tournevis) / Regulador de caudal unidireccional orientable (regulación mediante destornillador) / Controlador de fluxo unidireccional ajustável (ajuste de chave de fendas) / Jednokierunkowy regulator przepływu (regulacja śrubokrętem) / Çekvalfli hız ayar valfi (ayarlama tornavida ile) / 可调节的单向流动控制器 (通过螺丝刀调节) / 메ーター아웃·フロー컨트롤러 (ネジ調節タイプ) / 단방향 조정 유량 제어기 (드라이버로 조정)

RG.	NB	NA [mm]
RG.559000002	M5	Ø4
RG.559000003	1/8	Ø4
RG.559000007	M5	Ø6
RG.559000008	1/8	Ø6
RG.559000010	1/8	Ø8
RG.559000011	1/4	Ø8



Regolatore di flusso in linea unidirezionale tubo-tubo / Tube in-line unidirectional flow controller / Einweg-Durchflussregler in-line Rohr-Rohr / Régulateur de débit en ligne unidirectionnel tube-tube / Regulador de caudal en línea unidireccional, tubo-tubo / Tubo em linha regulador de fluxo unidireccional / Jednokierunkowy szeregowy regulator przepływu / Hat tipi hortum giriş ve çıkışlı çekvalfli hız ayar valfi / 管-管间使用的同轴的单向流量调节器 / ワンタッチ継手・ユニオン型・フローコントローラー / 파이프/파이브 인라인 단방향 유량 조절기

RG.	NC [mm]
RG.559400001	Ø6
RG.559400002	Ø8



Regolatore di pressione in linea tubo-tubo / Tube in line pressure regulator / Druckregler für Leitungseinbau Rohr-Rohr / Régulateur de pression en ligne tube-tube / Regulador de presión en línea tubo-tubo / Regulador de pressão em linha / Regulator ciśnienia / Hat tipi basınç regülatörü / 软管间的内置压力调节器 / インライン型プレッシャーレギュレータ / 튜브 배관 인라인 압력 조절기

RG.	NC [mm]
RG.559700001 <b>NEW</b>	Ø6
RG.559700002 <b>NEW</b>	Ø8



Nipplo cilindrico / Nipple (parallel) / Doppelnippel zylindrisch / Nipple double, cylindrique / Niple igual cilíndrico / Casquilho duplo cilíndrico / Złącza cylindryczna / Nipel / 螺母 (平行) / 同径ニップル (オス×オス、平行ねじ) / 니플 (평행)

RG.	ND
RG.020100001B5NB	M5 (1)
RG.02010000102NB	1/8 (1)
RG.02010000103NB	1/4 (1)

(1) Confezione da 10 pezzi / 10 pieces package / 10 Stück Packung / Vendu par 10 pièces / Paquete de 10 piezas / Embalagem de 10 peças / 10 sztuk w opakowaniu / Her paket 10 Adettir / 10个一包 / 一袋10個入 / 10피스 패키지



Nipplo di riduzione cilindrico / Reducing nipple (parallel) / Doppelnippel reduziert zylindrisch / Nipple double inégal, cylindrique / Casquilho duplo de redução cilíndrico / Reducing nipple (parallel) / Złącza cylindryczna redukcyjna / Orantılı nipel / 螺纹转接头 (平行) / 違径ニップル (オス×オス、平行ねじ) / 이경 니플 (평행)

RG.	NE	NF
RG.0203000010WNB	M5	1/8 (1)
RG.020300001ATNB	1/8	1/4 (1)



Riduzione cilindrica / Reducer (parallel) / Reduzierstück zylindrisch / Réduction cylindrique / Reducción cilíndrico / Redução cilíndrico / Redukcja cylindryczna / Lüle / 转接头 (平行) / 레듀서 (オス×メス、平行ねじ) / 역제기 (평행)

RG.	NG	NH
RG.0205000012WNB	1/8	1/8 (1)
RG.020500001ATNB	1/8	1/4 (1)
RG.0205000016WNB	1/4	1/4 (1)

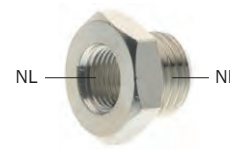

Riduzione cilindrica / Reducer (parallel) / Reduzierstück zylindrisch / Réduction cylindrique / Reducción cilíndrico / Redução cilíndrico / Redukcja cylindryczna / Redüksiyon / 转接头 (平行) / 레듀서 (オス×メス、平行ねじ) / 역제기 (평행)

RG.	NI	NL
RG.0209000010WNT	1/8	M5 (1)
RG.0209000015WNT	1/4	1/8 (1)

**Raccordi**  
**Fittings**  
**Fittings Raccords**  
**Raccords**  
**Racordaje**  
**Racord**  
**Złącza**  
**Rakorlar**  
**接头**  
**フィッティング**  
**피팅**



Manicotto / Sleeve / Muffe / Manchon / Manguito / Racord de passagem / Tuleja /  
 Manşon / 套管 / 同径スリーブ (メス×メス、平行ねじ) / 슬리브

**RG.**

NM

<b>RG.030000001B5NB</b>	M5	(1)
<b>RG.03000000102NB</b>	1/8	(1)
<b>RG.03000000103NB</b>	1/4	(1)



Tappo maschio cilindrico esagono incassato con O-Ring NBR / Male plug (parallel) with  
 exagon embedded and NBR O-Ring / Gewindestopfen zylindrisch Innensechskant mit  
 O-Ring NBR / Bouchon 6 pans creux mâle, cylindrique avec joint NBR / Tapón macho  
 cilíndrico con hexágono interior, provisto de junta tórica en NBR / Tampão macho  
 cilíndrico hexagonal interior com O-ring NBR / Zaślepka męska z gniazdem imbusowym,  
 z O-ringiem z NBR / NBR O-Ring'li körtapa / 帶嵌入式六边形和NBR材质O型圈的塞子  
 / 六角穴付プラグ (平行ねじ、Oリング付) / 6각형 내장 및 NBR O-링이 장착된 수 플러그 (평행)

**RG.**

NN

<b>RG.0301500005</b>	M5	(1)
<b>RG.0301500001</b>	1/8	(1)
<b>RG.0301500002</b>	1/4	(1)



Silenziatore / Silencer / Schalldämpfer / Silencieux / Silenciador / Silenciador / Tlumik  
 / Susturucu / 消音器 / サイレンサー / 사일렌서

**RG.**

NO

<b>RG.0702000001</b>	M5	(1)
<b>RG.0702000002</b>	1/8	(1)
<b>RG.0702000003</b>	1/4	(1)

(1)

Confezione da 10 pezzi / 10 pieces package / 10 Stück Packung / Vendu par 10 pièces  
 / Paquete de 10 piezas / Embalagem de 10 peças / 10 sztuk w opakowaniu / Her  
 paket 10 Adettir / 10个一包 / 一袋10個入 / 10피스 패키지

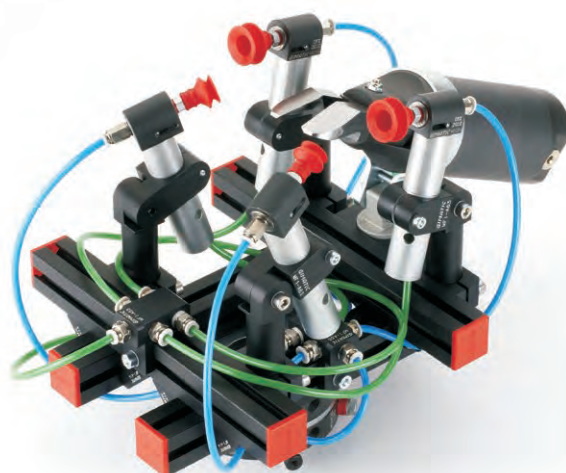

Sensori magnetici per cave a "T"  
 Magnetic sensors for "T" slot  
 Magnetische sensoren für "T" nuten  
 Capteur magnétique pour rainures à "T"  
 Sensores magnéticos para ranuras en forma de "T"  
 Sensor magnético para ranhuras em "T"  
 Czujniki magnetyczne dla szczelin „T”  
 Manyetik sensör T slot  
 T槽磁传感器  
 T型溝用・磁気近接センサー  
 “T” 슬롯용 자기센서

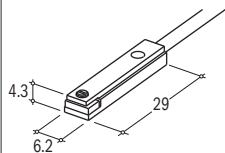

SL-G			m [g]
SL3N203-G	PNP	M8 connector	5
SL4N225-G	PNP	2.5m cable	23
SL3M203-G	NPN	M8 connector	5
SL4M225-G	NPN	2.5m cable	23

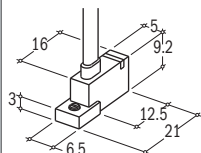

SC-Y			m [g]
SC3N203Y	PNP	M8 connector	5
SC4N225Y	PNP	2.5m cable	23

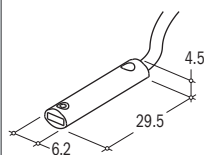

SA-G			m [g]
SA3N203-G	PNP	M8 connector	4
SA4N225-G	PNP	2.5m cable	22
SA3M203-G	NPN	M8 connector	4
SA4M225-G	NPN	2.5m cable	22

Accessori per sensori magnetici  
 Magnetic sensors accessories  
 Zubehör magnetische sensoren  
 Accessoires pour capteur magnétique  
 Accesorios para sensores magnéticos  
 Acessórios para sensor magnético  
 Akcesoria czujników magnetycznych  
 Manyetik sensör aksesuarları  
 磁传感器配件  
 磁気近接センサー用アクセサリ  
 자기 센서 액세서리들

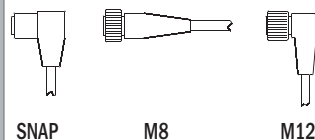

Connettore / Connector / Steckverbinder / Connecteurs /  
 Conector / Conectores / Łącznik / Bağlantı / 接头 / 電気配線用コネクタ / 커넥터

CF			m [g]
CFSM890225		SNAP	50
CFSM890325		SNAP	50
CFGM800225		M8	53
CFGM800325		M8	53
CFGM1290225		M12	57
CFGM1290325		M12	57
CMGM800310CFGM8003	NEW		37
CMGM800320CFGM8003	NEW		64
CMGM890310CFGM8003	NEW		38
CMGM890320CFGM8003	NEW		65



Connettori M8 a cablare / M8 male wiring connectors / M8 Kabelverbinder /  
 Connecteurs M8 à câbler / Conectores M8 para cablear / Conectores M8 a ligar /  
 Złącza przyłączeniowe M8 / M8 erkek kablo konektörleri / 可选的公的M8线连接器 / オプションのM8オス配線コネクタ / 선택적 M8 수 와이어링 커넥터

CF			m [g]
CFGM800300	NEW		11
CMGM800300	NEW		11

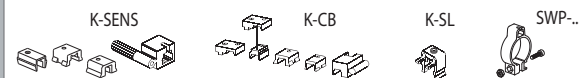

Adattatori per cave / Slot adapters / Passstücke für nuten / Adaptateurs pour rainures  
 / Adaptadores para ranuras / Adaptadores para ranhuras / Adaptery do gniazd / Slot  
 adaptörleri / 槽适配器 / 센서取付用アダプター / 슬롯 어댑터들

K		m [g]
K-SENS		1
K-CB		8
K-SL		5
SWP-014		2
SWP-020		2
SWP-030		2
SWP-050		2

Sensori magnetici per cave a "C"  
 Magnetic sensors for "C" slot  
 Magnetische sensoren für "C" nuten  
 Capteur magnétique pour rainures à "C"  
 Sensores magnéticos para ranuras en forma de "C"  
 Sensor magnético para ranhuras em "C"  
 Czujniki magnetyczne dla szczelin „C”  
 Manyetik sensör C slot  
 C槽磁传感器  
 C型溝用・磁気近接センサー  
 “C” 슬롯용 자기센서

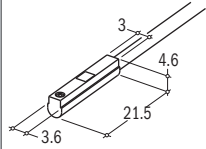

<b>SS-G</b>			m [g]
<b>SS3N203-G</b>	PNP	M8 connector	4
<b>SS4N225-G</b>	PNP	2.5m cable	22
<b>SS3M203-G</b>	NPN	M8 connector	4
<b>SS4M225-G</b>	NPN	2.5m cable	22

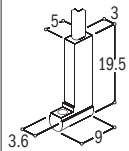

<b>SN-G</b>			m [g]
<b>SN3N203-G</b>	PNP	M8 connector	4
<b>SN4N225-G</b>	PNP	2.5m cable	22
<b>SN3M203-G</b>	NPN	M8 connector	4
<b>SN4M225-G</b>	NPN	2.5m cable	22

Sensori induttivi  
 Inductive sensors  
 Induktive Sensoren  
 Capteurs inductifs  
 Sensores inductivos  
 Sensores indutivos  
 Czujniki indukcyjne  
 İndüktif sensör  
 电感式传感器  
 誘導型近接センサー  
 인덕티브 센서



<b>SI</b>			m [g]
<b>SI4M225-G</b>	Ø4 NPN	2.5m cable	20
<b>SI4N225-G</b>	Ø4 PNP	2.5m cable	20
<b>SIS4M225-G</b>	<b>NEW</b> Ø3 NPN	2.5m cable	20
<b>SIS4N225-G</b>	<b>NEW</b> Ø3 PNP	2.5m cable	20



SGP-32-S

Sensori d'urto  
Shock sensors  
Schocksensoren  
Détecteur de choc  
Sensores de golpes  
Detetor de choque  
Czujniki wstrząsów  
Şok sensörler  
震动传感器  
アクチュエータ用ショックセンサー  
충격 센서들



SG	m [g]
SG3A2-G	17
SG3N2-G	17
SG3M2-G	17

Sensori ultrasonici  
Ultrasonic sensors  
Ultraschallsensoren  
Capteurs ultrasonores  
Sensor ultrasónico  
Sensores ultrasónicos  
Czujniki ultradźwiękowe  
Ultrasonik sensör  
超声波传感器  
超音波センサー  
초음파 센서들



SU			m [g]
SU9M2-G	NPN	M12 connector, 24 Vdc	15
SU9N2-G	PNP	M12 connector, 24 Vdc	15

Tester multi-sensore  
Multi-sensor tester  
Prüfgerät multi-sensor  
Testeur multi détecteurs  
Téster multisensor  
Testador multi detetores  
Tester z wieloma czujnikami  
Sensör test cihazı  
多传感器测试器  
センサー動作確認用テスター  
멀티 센서 테스트



SB2T	m [g]
SB2T	1400

Sensori ottici  
Optical sensors  
Optische Sensoren  
Capteurs optiques  
Sensores ópticos  
Sensor ótico  
Czujnik optyczny  
Optik Sensörler  
光学传感器  
光学式センサー  
광센서

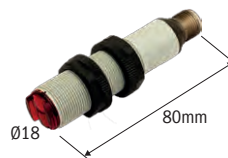

S0			m [g]	
S09M2-G	<b>NEW</b>	NPN	M12 connector, 24 Vdc	30
S09N2-G	<b>NEW</b>	PNP	M12 connector, 24 Vdc	30

<b>F [N]</b>	Forza	Force	Kraft	Force	Fuerza	Força	Sila	Kuvvet	力	力	힘
<b>C [Ncm]</b>	Coppia	Torque	Drehmoment	Couple	Par	Binário	Moment	Tork	扭矩	トルク	토크
<b>s [mm]</b>	Corsa	Stroke	Hub	Course	Carrera	Curso	Skok	Strok	行程	ストローク	스트로크
<b>m [g]</b>	Peso	Weight	Gewicht	Poids	Peso	Peso	Masa	Ağırlık	质量	重量	무게

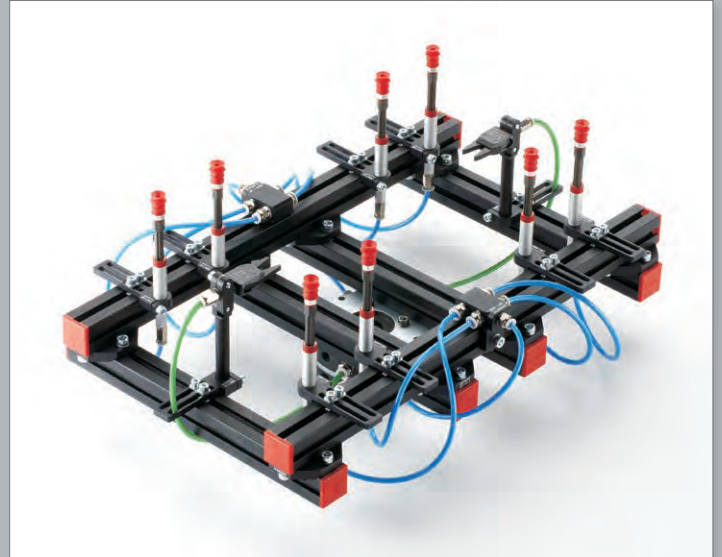
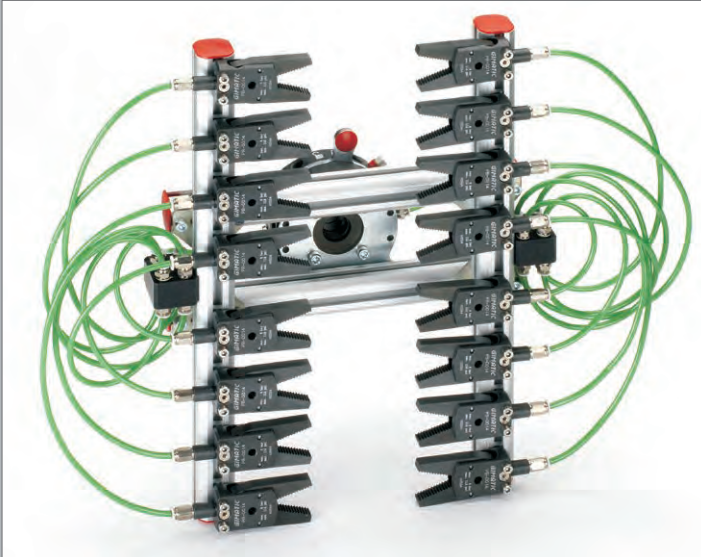

Tutte le forze e le coppie sono riferite ad una pressione di 6 bar.  
Le forze, o le coppie, delle pinze sono totali.

All forces and torques are related to a pressure of 6 bar.  
The forces, or the torques, of the grippers are total values.

Alle Kräfte und Drehmomente beziehen sich auf einen Druck von 6 bar.  
Die Kräfte oder die Drehmomente der Greifer sind Gesamtwerte.

Les données relatives à la force et au couple sont rapportées à la pression de 6 bars.  
Les forces, ou les couples, des pinces de préhension sont totales.

Riservati tutti i diritti, traduzioni incluse. Proibita ogni forma di riproduzione o trasmissione senza permesso scritto ed approvato da GIMATIC Srl. Con riserva di modifiche ed aggiornamenti in qualsiasi momento e senza alcun preavviso.

All rights reserved, including translation rights. No parts of this publication may be reproduced or transmitted in any form or by any means, electronic, mechanical, photocopying or otherwise, without the prior written permission of GIMATIC Srl. We reserve the right to make alterations.

Alle Rechte, einschließlich Übersetzungen, vorbehalten. Jede Form von Vervielfältigung oder Übermittlung ohne eine schriftliche und von GIMATIC Srl genehmigte Bevollmächtigung ist untersagt. Unter Vorbehalt von jederzeit und ohne Vorankündigung antragbaren Änderungen und Erneuerungen.

Réservés tous droits, traductions incluses. Toutes formes de reproduction ou transmission par quelque procédé que ce soit, interdites sans autorisation écrite préalable par GIMATIC Srl. Avec réserve de modifications et de mise à jour sans préavis.

Todas las fuerzas y los pares se refieren a una presión de 6 bar.  
Las fuerzas o los pares de las pinzas son totales.

Todas as forças e binários fazem referência à pressão de 6 bar.  
As forças, ou os binários, das pinças são valores totais.

Wszystkie wartości momentu i siły podano dla ciśnienia 6 barów.  
Wartości siły lub momentu chwytaków są wartościami całkowitymi.

Bütün kuvvet ve Tork değerleri 6 bar basınç ile geçerlidir. Kuvvet veya Tork tutucular için toplam değerdir.

Todos los derechos reservados, incluyendo los derechos de traducción. Ninguna parte de esta publicación puede ser reproducida o transmitida en ninguna forma y por ningún medio, sea electrónico, mecánico, fotocopia u otro, sin permiso previo por escrito de Gimatic Srl. La empresa se reserva el derecho de aportar modificaciones sin previo aviso.

Todos os direitos reservados, inclusas traduções. É proibida qualquer forma de reprodução ou transmissão sem a autorização escrita e aprovada pela GIMATIC Srl. Reservamo-nos o direito de efectuar modificações e actualizações em qualquer momento e sem aviso prévio.

Wszystkie prawa zastrzeżone wraz z prawami do tłumaczenia. Powielanie lub przekazywanie tego dokumentu w jakiegokolwiek formie i za pomocą jakichkolwiek środków, elektronicznych, mechanicznych, fotokopii i innych, bez pisemnej zgody GIMATIC Srl jest zabronione. Zastrzegamy sobie prawo do dokonania zmian bez powiadomienia.

Çeviri hakkı dahil her hakkı saklıdır. Bu yayının hiç bir kısmı Gimatic Srl'nin yetkili yazılı izni olmadan çoğaltılamaz veya elektronik, mekanik, fotokopi ve diğer yollarla, herhangi bir biçimde, yayınlanamaz. Değişiklik yapma hakkı bizde saklıdır.

所有的力和力矩都是在6bar的压力下。  
钳夹的力和扭矩是总值。

カタログに記載された力とトルクは、エア一圧力が0.6MPaのときの数値です。  
グリッパーの把持力とトルクは、合計の数値です。

모든 힘 및 토크는 6바 압력과 관련되어 있습니다.  
그리퍼의 힘 또는 토크는 총 값입니다.

GIMATIC版权所有。在无GIMATIC的书面授权下，不得以任何电子或书面的形式复制或传播本刊物。我们保留修改的权利。

弊社は、著作権を含めた著作権を保有しています。このパンフレット内のいかなる部分であっても、ジマテックの書面による事前の許可なく、電子的や機械的といった、あらゆる形式・手段であれ、複製・転載することは禁じられています。弊社は、事前の予告なく内容の変更を行う権利を有しますので、ご理解ご了承ください。

번역권 포함 판권 본사 소유. 본 간행물의 그 어떤 부분도 GIMATIC Srl 의 사전 서면 동의 없이 전자적, 기계적, 복사 또는 기타 그 어떤 방식으로든 재생산 또는 전송할 수 없습니다. 변형에 대한 권리는 본사에 있습니다.



Visitate il nostro sito ed avrete a disposizione tutti gli strumenti necessari con gli aggiornamenti, in tempo reale, sulle ultime novità di prodotto, i prezzi e la rete di vendita. L'offerta Gimatic, oltre ai prodotti della sezione PLASTICS mostrati in questa brochure, comprende una sezione HANDLING dedicata ai componenti per la manipolazione generale, una sezione SENSORS dedicata ai sensori per l'automazione ed una sezione MECHATRONICS dedicata agli attuatori elettrici.



Besuchen Sie unsere Website, dort finden Sie alle notwendigen technischen Informationen, die aktuellen Produktneheiten, Preislisten und eine Übersicht zur Vertriebsstruktur. Neben den in dieser Broschüre gezeigten Produkten der Rubrik PLASTICS enthält das Angebot von Gimatic die Rubrik HANDLING, die den Bestandteilen der allgemeinen Handhabung gewidmet ist, die Rubrik SENSORS, die Sensoren für die Automation umfasst, und die Rubrik MECHATRONICS, die elektrische Antriebe beinhaltet.



Visite nuestro sitio y tendrá a disposición todas las herramientas necesarias con todas las actualizaciones, en tiempo real, sobre las últimas novedades de los productos, los precios y la red de ventas. La oferta Gimatic, además de los productos de la sección PLASTICS indicados en este folleto, incluye una sección HANDLING dedicada a los componentes para la manipulación en general, una sección SENSORS dedicada a los sensores para la automatización y una sección MECHATRONICS dedicada a los actuadores eléctricos.



Zapraszamy do odwiedzenia naszej strony internetowej, która zapewni dostęp do niezbędnych narzędzi w czasie rzeczywistym, aktualności, cenników i sieci sprzedaży. Oprócz produktów opisanych w części niniejszej broszury TWORZYWA SZTUCZNE oferta Gimatic zawiera również dział TRANSPORT, obejmujący elementy pneumatyczne do ogólnych zastosowań transportowych, dział CZUJNIKI, dotyczący czujników dla układów automatyki, a także dział MECHATRONIKA poświęcony silownikom elektrycznym.



您可以通过登录我们的网站获得最新的新闻和销售网络信息。除宣传册中提及的器具外, Gimatic的产品还包括自动化部件, 传感器和电驱装置。



저희 웹사이트를 방문하시면 최근 제품 소식, 가격 목록, 판매 네트워크 등에 대한 실시간 업데이트와 함께 필요한 모든 도구를 이용하실 수 있습니다. Gimatic는 본 브로셔에 나와 있는 PLASTICS 제품 섹션만이 아니라 범용 취급 애플리케이션용 공압 부품인 HANDLING 섹션, 자동화를 위한 전용 센서인 SENSORS 섹션, 전기 센서 전용인 MECHATRONICS 섹션 등을 제공합니다.



Visit our website: you will have access to all the necessary tools with real-time updates on the latest news, prices and sales network. In addition to the products of the PLASTICS section shown in this brochure, the Gimatic offer includes a HANDLING section concerning pneumatic components for general handling applications and a SENSORS section dedicated to sensors for automation and a MECHATRONICS section dedicated to electric actuators.



Visitez notre site et vous aurez à disposition tous les instruments nécessaires avec toutes les mises à jour, en temps réel, sur les dernières nouveautés du produit, ainsi que la liste des prix et le réseau de vente. L'offre Gimatic, en dehors des produits de la section PLASTICS montrés dans cette brochure, comprend une section HANDLING, dédiée aux composants pour la manipulation générale, une section SENSORS, dédiée aux capteurs pour l'automatisation, et une section MECHATRONICS, dédiée aux actionneurs électriques.



Visite o nosso site e terá ao seu dispor todos os instrumentos necessários de atualização, em tempo real, para as últimas novidades dos produtos, assim como a lista de preços e a rede de vendas. A oferta Gimatic, para além dos produtos da secção PLASTICS ilustrados no presente folheto, inclui uma secção HANDLING, dedicada aos componentes para a manipulação geral, uma secção SENSORS, dedicada aos sensores para a automatização e uma secção MECHATRONICS dedicada aos atuadores elétricos.



Ürünlerimiz ve satış ağımızla ilgili en güncel bilgiye ulaşmak, yeni ürünlerimizden haberdar olmak için internet sitemizi ziyaret edin. Bu broşürde tanıtılan "Plastik" bölümüne ek olarak, genel taşıma uygulamaları için pnömatik ürünleri içeren "Taşıma Üniteleri" otomasyonda kullanılan "Sensör" bölümünü ve elektrikli iş ünitelerini de Gimatic'in ürün gamı içerisinde bulacaksınız.



我が社のホームページをご覧になったら、リアルタイムで製品に関する最新のニュース、価格、販売網などを知ることができます。Gimatic社のラインアップは、本パンフレットに掲載されているPLASTICS セクションの製品以外に一般のハンドリング部品に関するHANDLINGセクションと自動化用センサーのSENSORSセクションと電気アクチュエータのMECHATRONICSセクションを含む。

## H A N D L I N G



## P L A S T I C S

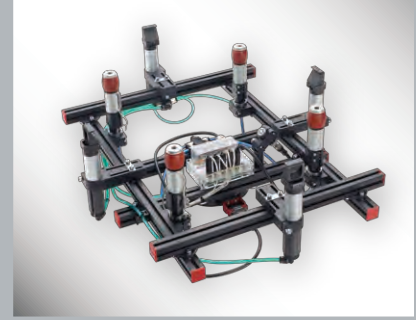

## S E N S O R S



## M E C H A T R O N I C S



Gimatic S.r.l.

Via Enzo Ferrari, 2/4 - 25030 Roncadelle (BS) - ITALIA

Tel. +39 030 2584655 - Fax +39 030 2583886

www.gimatic.com - info@gimatic.com



\* B R O - P L A S T - 2 0 1 6 \*